

2017 4

<

>

1

2025 12 3 -2025 12 30

15751229091



2025 11 29

1 110 /

45000Nm<sup>3</sup>/ 100 /  
110kV 110kV 110kV  
110kV

2025 1 2

<https://www.lygjc.com>

2×2475 / 2×2500 /  
1 26  
5 4  
2 3  
2 H14  
22m 18m 20m  
“ ”  
“ + +15m ”  
“ ” “ + + +20m ”  
“ ” “ + ”  
“ ” “ ” “ ”  
“ ” “ ” 711.99m<sup>2</sup>  
704.12m<sup>2</sup> 2484.18m<sup>2</sup> 2468.56m<sup>2</sup>  
847m<sup>3</sup> 1353.5m<sup>3</sup> 5800m<sup>3</sup> 6910 m<sup>3</sup>  
19400m<sup>3</sup> 20776m<sup>3</sup>

W2101\_

W4101\_

W5101\_

GB 13458-2013  
GB18918-2002 A  
DB32/939-2020 2 3 4

GB/T 19923-2024

GB/T 50050-2017

“ ”

1

3 44m

DA003~DA005

64m

DA006

2

80m

DA002

3

5

+ 2 45m DA013~DA014

20m DA016

40m

DA015

2

32m DA035~DA036 1 20m DA037

+ + 20m

DA011

3 24m DA017~DA019

36m DA012

2 36m DA020~DA021 2

30m DA030~DA031

+ 20m DA022

20m DA034

2 30m DA032~DA033

6

15m DA038

1# 32m DA008

2# 33m DA009

3# 49m DA010

21m DA023

1# 45m DA024

2# 45m DA025

3# 45m DA026

1 15m DA027

2 15m DA028

3 15m DA029

7

+

15m DA054

8

15m DA039

9

15m DA040

10

+

13 17m DA041~DA53

11

NOx SCR

15m DA001

85

100dB A

704.12m<sup>2</sup>

2468.56m<sup>2</sup>

1

GB50016-2014 2018

GB50058-2014

2

13376m<sup>3</sup> 7400m<sup>3</sup>

3

4

5

DA006 DA039 DA054

GB/T 19923-2024

GB/T 50050-2017

GB 13458-2013

DA001

DB32/ 4385-2022

DA002

GB14554-93 2

GB31571-2015 6 NMHC

DB32/4041-2021 1

DA003~DA005

DA008~DA010		DA012		DA023
DA017~DA019		DA022	DA034	DA032
DA033	1#~3#	DA024~DA026		1~3
DA027~DA029		DA020	DA021	DA030
DA038			DB32/4041-2021	1
	DA007			
GB31573-2015	4	DA011	DA013~DA016	DA035~DA037
		GB14554-93	2	DA040
			DB32/3151-2016	1
DA039	NMHC		DB32/4041-2021	1
DA040	DA041	DA043	DA044	DA047
		GB14554-93	2	NMHC
		DB32/4041-2021	1	DA054
		GB14554-93	2	NMHC
		DB32/4041-2021	1	
DB32/4041-2021	3			
GB14554-93	1			
DB32/3151-2016	2			
DB32/4041-2021	2			
GB12348-2008	3			
		GB12348-2008	4	

## 五、验收结论

该二洪碱业右限公司搬迁升级改造项目实施了环评报告书及其批复意见中

的各项环保要求，项目废水、废气、噪声污染物的排放达到相关标准，建立了完善的环境管理制度，不存在《建设项目竣工环境保护验收暂行办法》中不符合建设项目竣工环境保护验收的九种情形。验收组一致同意项目环保设施通过验收。

## 六、后续要求

- 1、加强固废管理，做好相关台账，按规定申报、填写固废转移联单。
- 2、加强环保设施的日常维护和管理，确保环保设施正常运行，各项污染物稳定达标排放。
- 3、加强环境风险隐患排查，定期开展突发环境事件应急演练，防范环境事故风险。

## 七、验收人员信息

李俊峰  
庄俊友

王峰  
王义  
姚坤

公司搬迁升级改造项目  
主验收会议验收组签到表

时间: 2025.11.29

姓名	职务 (职称)	联系电话
王中	高级工程师	13812150504
王中	高工	13961379121
王中	高工	13815667280
王中	高级工程师	1891337855
王中	高级工程师	13855426215
王中	工程师	18796399090
王中	高工	13812127892
王中	高工	13775596806
王中	高工	15751229091
王中	高级工程师	18915743206
王中	高工	18114017067
王中	工程师	187 41528

王中

王中



⋮  
⋮

0518-86088666

025-86773123

0518-86081111

025-86773123

222200

210042

1	.....	1
2	.....	4
2.1	.....	4
2.2	.....	4
2.3	.....	5
2.3	.....	5
3	.....	6
3.1	.....	6
3.2	.....	10
3.3	.....	54
3.4	.....	56
3.5	.....	58
3.6	.....	86
4	.....	93
4.1	.....	93
4.2	.....	98
4.3	.....	114
4.4	.....	125
4.5	.....	130
4.6	.....	139
4.7	.....	140
4.8	“ ” .....	141
5	.....	145
5.1	.....	145
5.2	.....	145
5.3 “ ”	.....	151
6	.....	156
6.1	.....	156
6.2	.....	159
6.3	.....	160
6.4	.....	161
6.5	.....	161
7	.....	162
7.1	.....	162
7.2	.....	162
7.3	.....	162
7.4	.....	167
8	.....	168
8.1	.....	168
8.2	.....	169
8.3	.....	172
8.4	.....	172
8.5	.....	172

8.6	.....	173
8.7	.....	173
9	.....	175
9.1	.....	175
9.2	.....	176
10	.....	200
10.1	.....	200
10.2	.....	201

1  
2  
3  
4

1  
2

2022 6

3  
4  
5  
6  
7  
8  
9  
10

11  
12

13  
14  
15

**1**

H<sub>2</sub>SO<sub>4</sub>

HCl

NaOH

Na<sub>2</sub>CO<sub>3</sub>

HNO<sub>3</sub>

“

”

50%

“ ” “ +  
 +15m ” “ ”  
 “ + + +20m ”  
 “ + ” “ ”  
 ” “ ” “ ”  
 “ ” 711.99m<sup>2</sup> 704.12m<sup>2</sup>  
 2484.18m<sup>2</sup> 2468.56m<sup>2</sup>  
 847m<sup>3</sup> 1353.5m<sup>3</sup>  
 5800m<sup>3</sup> 6910 m<sup>3</sup>  
 19400m<sup>3</sup> 20776m<sup>3</sup>  
 < >  
 2017 4

2025 8 12 ~8 27 2025  
 11 3 ~11 4

1-1

**1-1**

1		
2		
3		
4		1
5		2021 1 1
6		2022 5
7		2022 5 28 2022 6
8		2022 6 2025 4 2025 4
9		91320700MA1MFBW470003V 2
10		2025 7
11		

12		2025 7
13		2025 8 11



3

2020 688

4

2021 122

5

HJ 819-2017

6

HJ 1138-2020

7

HJ 948.1-2018

### 2.3

1

2022 5

1

2022 6

### 2.3

1

2

3

4

5

### 3

#### 3.1

##### 3.1.1

119°2 50 ~119°52 9

34°11 45 ~34°38 50

28                      135                      310                      397  
471

324                      G228

1

##### 3.1.2

1

3.1.2-1

###### 3.1.2-1

	/m			m		
	X	Y				
	750082.69	3812623.68		1410	800	
	750904.46	3817719.61		2200	2300	

2

3.1.2-2

###### 3.1.2-2

		m		
--	--	---	--	--

		<b>m</b>		
	SE	1342		III
	SSW	131		IV
	E	4140	/	IV

3

4

200m

0w 3

10.15

4

7

3.1.2-4

			km <sup>2</sup>		km	
		500	132.18	SE	0.423	
	204					
		71.7	85.89	SE	3.5	
	68					
		1000	39.73	E	4.3	
		100m	19.3	NW	8.1	

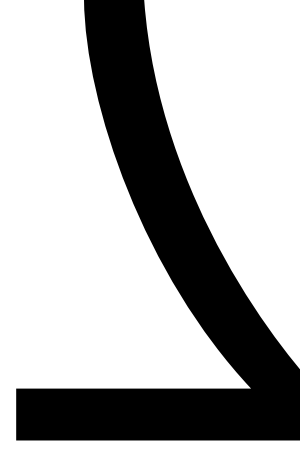
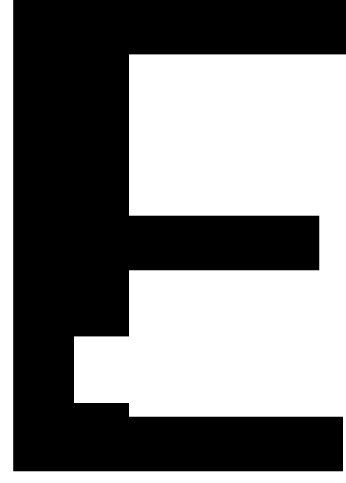

CO<sub>2</sub>

K&E n-e

7

2

3

## 3.2

### 3.2.1

3.2.1-1

#### 3.2.1-1

1		2022 6		
2	110	2023 3		
3	110	2023 17		
4		2023 2026		

3.2.1-1

**3.2.1-2**

		/		/		%
		80	56.8	2402.4	1705.61	71.00
		24.592	20.57	738.5	617.83	83.66
		110	78.84	3303.3	2367.61	71.67
		0.4714	0.25	14.16	7.41	52.35
		6.2	4.56	186.19	136.94	73.55
		5.3256	4	159.93	120.22	75.17
		2.16	1.67	64.86	50.26	77.48
		1.12	0.93	33.63	27.96	83.12
		4.68	39.44	1214.17	1184.39	97.55
		1.6	1.17	48.05	35.02	72.89

**3.2.2**

### 3.2.2-1

4.5×10<sup>4</sup> / O<sub>2</sub>

103000 / CO+H<sub>2</sub>

26.95 Nm<sup>3</sup>

		0	1446 t/h		
			160t/h		
		594.4	826.2 t/h		
			+		
			16500t/h		
			6000t/h		
			28000t/h		
			450t/h		
			/	/	/
			4203m <sup>2</sup>	3581.86m <sup>2</sup>	3581.86m <sup>2</sup>
			3507m <sup>2</sup>	4280.17m <sup>2</sup>	4280.17m <sup>2</sup>

		5684m <sup>2</sup>	6988.16m <sup>2</sup>	6988.16m <sup>2</sup>	
		2825.59m <sup>2</sup>	4113m <sup>2</sup>	4113m <sup>2</sup>	
		2417.25m <sup>2</sup>	1616.22m <sup>2</sup>	1616.22m <sup>2</sup>	
		3143.66m <sup>2</sup>	3273.66m <sup>2</sup>	3273.66m <sup>2</sup>	
		3			
		1			
		1	1		
		1	1		
		3 3500m <sup>3</sup> 1 VN=500m <sup>3</sup> 2 500m <sup>3</sup> 1 1500m <sup>3</sup> 1 1500m <sup>3</sup> 1 14m <sup>3</sup>			

1 50m<sup>3</sup> 1 13m<sup>3</sup>  
1 8m<sup>3</sup>  
2 125m<sup>3</sup>  
7

3 15000m<sup>3</sup>/h  
H<sub>2</sub>S +  
NH<sub>3</sub> 3544m<sup>3</sup>/h  
H<sub>2</sub>S 1 44657m<sup>3</sup>/h  
SO<sub>2</sub>  
H<sub>2</sub>S 1 2944m<sup>3</sup>/h  
NO<sub>x</sub>  
1 +

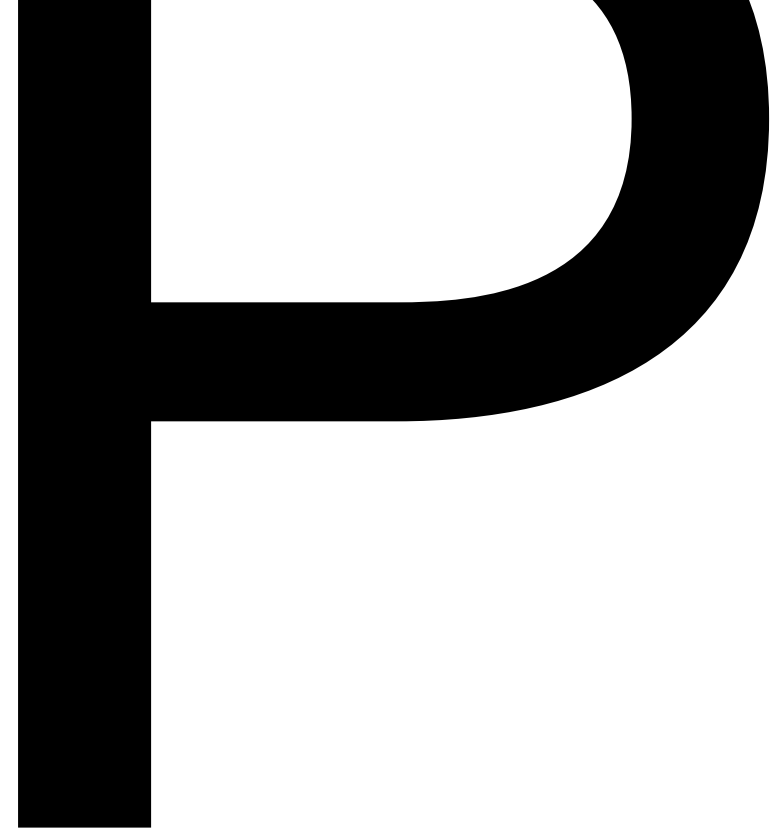

\*6

Ö

ý

				5000m <sup>3</sup> /h 5000m <sup>3</sup> /h	2100m <sup>3</sup> /h 27000m <sup>3</sup> /h 27000m <sup>3</sup> /h	11000m <sup>3</sup> /h 11000m <sup>3</sup> /h 6053m <sup>3</sup> /h 21000m <sup>3</sup> /h 2100m <sup>3</sup> /h 27000m <sup>3</sup> /h 27000m <sup>3</sup> /h	
				/	1 8200m <sup>3</sup> /h	1 8200m <sup>3</sup> /h	
				10 21000m <sup>3</sup> /h 27000m <sup>3</sup> /h 11000m <sup>3</sup> /h 11000m <sup>3</sup> /h 11000m <sup>3</sup> /h 11000m <sup>3</sup> /h 11000m <sup>3</sup> /h 10000m <sup>3</sup> /h 10000m <sup>3</sup> /h 10000m <sup>3</sup> /h	10 21000m <sup>3</sup> /h 27000m <sup>3</sup> /h 11000m <sup>3</sup> /h 11000m <sup>3</sup> /h 11000m <sup>3</sup> /h 11000m <sup>3</sup> /h 11000m <sup>3</sup> /h 10000m <sup>3</sup> /h 10000m <sup>3</sup> /h 10000m <sup>3</sup> /h	10 21000m <sup>3</sup> /h 27000m <sup>3</sup> /h 11000m <sup>3</sup> /h 11000m <sup>3</sup> /h 11000m <sup>3</sup> /h 11000m <sup>3</sup> /h 11000m <sup>3</sup> /h 10000m <sup>3</sup> /h 10000m <sup>3</sup> /h 10000m <sup>3</sup> /h	
		H <sub>2</sub> S NH <sub>3</sub> NMHC	1	+ 10000m <sup>3</sup> /h			
		NMHC	1	15000m <sup>3</sup> /h			
			1	271m <sup>3</sup> /h			
		NH <sub>3</sub> NMHC	1	8000m <sup>3</sup> /h	26 4000m <sup>3</sup> /h 4000m <sup>3</sup> /h 4000m <sup>3</sup> /h 4000m <sup>3</sup> /h 4000m <sup>3</sup> /h 4000m <sup>3</sup> /h 1500m <sup>3</sup> /h 1500m <sup>3</sup> /h 1000m <sup>3</sup> /h 1000m <sup>3</sup> /h 880m <sup>3</sup> /h 880m <sup>3</sup> /h 880m <sup>3</sup> /h 880m <sup>3</sup> /h	26 4000m <sup>3</sup> /h 4000m <sup>3</sup> /h 4000m <sup>3</sup> /h 4000m <sup>3</sup> /h 4000m <sup>3</sup> /h 1500m <sup>3</sup> /h 1500m <sup>3</sup> /h 1000m <sup>3</sup> /h 1000m <sup>3</sup> /h 880m <sup>3</sup> /h 880m <sup>3</sup> /h 880m <sup>3</sup> /h	



### 3.2.3

3.2.3-1~3.2.3-8

#### 3.2.3-1

1			22700kW	1	1	
2			17100kW	1	1	
3		4500×26689		1	1	
4		3600×28057		1	1	
5			45kW	1	2	1
6			55kW	1	2	1
7				2	1	
8		4200×21310	285m <sup>3</sup>	2	2	
9			2200	1	1	
10				2	4	2
11		98000Nm <sup>3</sup> /hr		1	1	
12		3640×22290		1	1	
13		3936×29300		1	1	
14		2928×49000		1	1	
15		916×17790		1	1	
16				1	2	1
17				1	6	5
18				1	1	
19		/		1	2	1
20		/		1	1	
21		/		1	1	

22	/					1		1	
23					315kW	1	2		1
24					250kW	1	2		1
25	/				Α.Ε), υπερεπι- Β. Ε	2	/		2
26					50000Nm <sup>3</sup> /hr	2		1	1
27					5325×2550×18300	2		1	1
28					6600×4600	1		1	
29					-12.9/9.6	1		1	
30					12000×13600	1		1	
31					1500m <sup>3</sup>	1		1	
32	Α				355kW	1		1	
33					45kW	1		1	
34					12000×13600	1		1	
35					1500m <sup>3</sup>	1		1	
36					250kW	1		1	
37					15kW	1		1	
38					30kW	1		1	
39					15kW	1	2		1
40					40000Nm <sup>3</sup> /h	1		1	
41					45000Nm <sup>3</sup> /h	2		1	
42					800Nm <sup>3</sup> /h	1		1	
43					8000×11335	1		1	
44					500m <sup>3</sup>	1		1	
45					15kW	2		1	1
46					/	1		/	1
					2000Nm <sup>3</sup> /h	1		2	1
					/	1		/	1

3.2.3-2

1		5100×8950×11500mm				3	3
2		3400×6232mm	48m <sup>3</sup>			1	1
3		4200×2200mm	30m <sup>3</sup>			1	1
4		4000×5278	136m			2	2
5		3400×4693MM	35.5m <sup>3</sup>			3	3
6		NJGC-30-800 1.5kW	36531.6 kg/h	4kW		3	3
7		MBS3660 10KV	Y×KK450-6	1000kW		3	3
8		HZK80-50-200AI 160M2-2/15kW		YE5		2	2
9		VS4 FYB100-65-250 15kW	L=2.7m	YE5-160L-4		2	2
10		LJ4-MF2000/0.3-BY×-IV 2.2kW/380V/4 /IP55/WF1				3	3
11		MJ60-115	90kW			6	6
12		RF107-15kW/59rpm				1	1
13		RF107-15kW/81rpm				3	3
14		RF107-11kW/59rpm				2	2
15		MD 5t 0.8kW	14m 7.5/0.8kW	12m		1	1
16		QD 32t/5t 58.8m	21m 2×2.2kW	28.5m 2×2.2kW		1	1
			2.2/18.5kW	0.8/7.5kW			
1		/	6.5MPaG	235		3	3

		1.2m <sup>3</sup>				
2		D 3600×21636		3	3	
3		D + DN3800 H 28090mm 2165 3055		3	3	
4		10500×H=10000 T-T 1023m <sup>3</sup>		2	2	
5		1400×65×26010 35.4m <sup>3</sup>		2	2	
6		1200×14×6965 6.1m <sup>3</sup>		1	1	
7		D 1500×L=4000mm T-T 8.83m <sup>3</sup>		3	3	
8		D 1500×L=7000mm T-T 14.1m <sup>3</sup>		3	3	
9		SAD 2200×H=4000mm T-T 19.5m <sup>3</sup>		3	3	
10		2800×8070 43m <sup>3</sup>		3	3	
11		× × 13751×2961×4000 56.9/40.2		3	3	
12		/		1	/	1
13		/		1	/	1
14		1200×14×6965 6.1m <sup>3</sup>		1	1	
15		273×1670 83×670 0.056m <sup>3</sup> 2 1.25m <sup>2</sup> 5μm		1	1	
16		2000×L=6670 18.9m <sup>3</sup>		1	1	
17		3D095MH60/9.8 60m <sup>3</sup> /h 9.8Mpa G 47rpm 180mm 300mm DN200 DN150 3 380V 3PH 50Hz 200kW 5-50Hz IP55 F B 1500rpm		3	3	

18		SDZA80-250 1450rpm 148 64%	44m <sup>3</sup> /h 15MPa 380V 5.5kW	20m 2m		6	6
		YB×5132S-4WF1					
19		SAJZM125-100-400 1450rpm 104 45%	75m <sup>3</sup> /h 2MPa 380V 30kW	40m 3m		6	6
		YBPT3 200L-4WF1					
20		SDZA100-400 2950rpm 241	256m <sup>3</sup> /h 15MPa 380V 160kW	135m 3.5m		6	6
21		SLDB720-160 2950rpm 2300×900×790mm	559m <sup>3</sup> /h 355kW	160m 604kg		6	6
22			/			3	/
23			/			1	/
24		80ZWB40/30-7.5 YB×5132S2-2WF2TH	7.5kW	2900r/min		1	1
25		110kW/27rpm 110kW/27rpm	IE4-110kW-4P-IP55-F			2	2
26			/			1	/
27		LYGJY/GBL1.1×20 12850mm 10200mm L×W×H 2.5 20t/h 56.9m <sup>3</sup>	21300mm 35° 22779×8000×~10200 0.6-3m/min 30×108			3	3
28			7.5kW			3	3

29					4	4	
30		HTSC-LK DaC-302 7.9MPa	2000KG 30800Nm R2023-10-3 280 4.5m <sup>3</sup>	II	3	3	
31		7.74kW	5t	+	1	1	
32		2×13kW	10t	2×0.8kW	1	1	
33		0.8/7.5kW	5t	0.8kW	1	1	
34		2200mm	FAOS810C 1.0m/s N=30kW	2000× 2900×	1	1	
1		II /D 192 MPa	80m <sup>3</sup>	2022648 1.62 1.2MPa /1.8	3	3	
2			2400×4000	23.5m <sup>3</sup>	3	3	
3			2600×4000	28m <sup>3</sup>	3	3	
4			3000×4000	38.5m <sup>3</sup>	3	3	
5		61 m <sup>3</sup> DN2500 DN3000		71.3m <sup>3</sup>	1	1	
6			/		1	/	1
7			23000×5200	2430m <sup>3</sup>	1	2	1
8			7000×7000 T-T	550m <sup>3</sup>	1	1	
9			2600×3262	16m <sup>3</sup>	1	2	1
10			1200×2268	4m <sup>3</sup>	1	1	

11		2800×6870	24m <sup>3</sup>		1	1	
12		3600×5570	49m <sup>3</sup>		1	1	
13			/		1	/	1
14		29000×12000×4000			1	1	
15		1200mm	/	BEU	283.4m <sup>2</sup>	3	3
		6000mm					
16		D	BEM	33.2m <sup>2</sup>	1	1	
		600mm	2000mm				
17		D	BES	339×2 m <sup>2</sup>	4	2	2
		1100mm	6000mm				
18		D	BEU	64m <sup>2</sup>	3	3	
		700mm	3000mm				
19		3kW×2+2.2kW/0.08rpm			2	2	
		IE4-3kW-4P-IP55-F	IE4-2.2kW-4P-IP55-F				
20		RF77-4kW/92rpm			2	2	
		IE4-4kW-4P-IP55-F					
21		2BEA-204-0			3	2	1
		YB×5-280S-6/45kW/380V/dIICT4/IP55/WF1					
		12m2	304SS				
22		ZDP140-80	124m <sup>3</sup> /h	735m	6	6	
		2980rpm	450kW	7.8MPa			
		149	11MPa				
		306mm	4.5m				
23		ZHA80-100-290	82m <sup>3</sup> /h	100m	3	3	
		2910rpm	2.5MPa				
		260	380V	45kW			
		2300×900×790mm		604kg			
24			/		4	/	4

25	HZ150-125-500I 1450rpm 150	380V	158m <sup>3</sup> /h 1	6MPa 90kW	90m 551kg	3	3
26	LJ4-MF2000/0.6-BY×- 0.6MPa	2.2kW	2000L/h				

		YBX3 -2WF2	315kW 10kW			
		2980rpm IP55 F				
2		2200×52+4×16890	47.5m <sup>3</sup>		1	1
3		1400×8×22760	25.7m <sup>3</sup>		1	1
4		DN3600×10250	53.2m <sup>3</sup>		2	1
5	1#	D	DN2600×7800		1	1
		16.3m <sup>3</sup>				
6	2#	D	DN1600×4800		1	1
		10.7m <sup>3</sup>				
7		1600×16×6070	7.5m <sup>3</sup>		1	1
8		2700×88+4×12000	48m <sup>3</sup>		1	1
9		2200×60+4×8800	24m <sup>3</sup>		1	1
10		/			1	1
11		1000×8×4615	2.8m <sup>3</sup>		1	1
12		D	DN1400×4000		1	1
		7.1m <sup>3</sup>				
13		DN 2400			1	1
		78.3m <sup>3</sup>	68m <sup>3</sup>			
		DN3000				
14	1#	DN3000	~16205		1	1
		60.2m <sup>2</sup>				
15	2#	DN2800	~15935		1	1
		51.5m <sup>2</sup>				
16		BES	465.2m <sup>2</sup> 1400×46+5×8261		1	1
17			3.88m <sup>3</sup>		1	1
18		BEM	246.2m <sup>2</sup> 1000×12×5791		1	1
19		BKU	D		1	1

		BKU 1800/2600mm	175 9000mm	m <sup>2</sup>				
20		BEM		1081m <sup>2</sup> 1400×12×12035		1	1	
21		BEM BFU		D 137.1m <sup>2</sup> 800mm 3500mm		1	1	
22		BEM BEM		D 34.1m <sup>2</sup> 600mm 2000mm		1	1	
23		BEM		489.4m <sup>2</sup> 1000×14×8731		1	1	
24		BEM		645m <sup>2</sup> 1200×14×10283		1	1	
25		/				1	1	
26	1#	×SZE100-250 YB×5 225M-1	45kW	2960rpm		1	1	
27	2#	×SZE80-250 37kW	2960rpm			1	1	
28		100XZE135×2 TZ BB2 d CT4 IP55 F		2 90kW 380V		6	4	2
29		SDZG160-110 BB5 2 F		/ 800kW 10000V d CT4 IP55		2	2	
30		×ZE155-67×9 TZ BB4 d CT4 IP55 F		2 355kW 10000V		2	2	
31		×ZE85-67×5 TZ BB4 d CT4 IP55 F		2 110kW 380V		2	2	
32		MZA40-250 15kW	2950r/min			1	1	

33					2	1	1
34					2	1	1
35	I	40t/h 100%	42dB A	H <sub>2</sub> O	1	1	
36	II	8t/h 100%	42dB A	H <sub>2</sub> O	1	1	

### 3.2.3-4

1		564m <sup>3</sup>	D	DN 3000×77740 4.2m	1	1	
2	CO <sub>2</sub>	314m <sup>33</sup>	D	CO <sub>2</sub> 2600×58350	1	1	
3	H <sub>2</sub> S	344m <sup>3</sup> 7m	D	DN 2600×64020	1	1	
4		163m <sup>3</sup> 6.5m	D	DN 2600/3600×25340	1	1	
5	/	142.8m <sup>3</sup>	D	DN 1400×27350 5m	1	1	
6		226m <sup>3</sup>	/	DN 4600×12090 H <sub>2</sub> O CO <sub>2</sub> N <sub>2</sub> CH <sub>3</sub> OH 5.5m	1	1	
7		2400/2800×15590	D	85.4m <sup>3</sup> DN 7m	1	1	
8		79.3m <sup>3</sup> 7m	D	DN 2400×9300	1	1	

1		12.10m <sup>3</sup>	D	/	DN 2000×3180	1	1
2		82.9m <sup>3</sup>	/		DN 3400×8000	1	1
3	H <sub>2</sub> S	0.95m <sup>3</sup>	D	H <sub>2</sub> S /	DN 800×1760	1	1
4		3.93m <sup>3</sup>	D	H <sub>2</sub> S /	DN 1200×3070	1	1
5	/CO <sub>2</sub>	2.50m <sup>3</sup>	D	/CO <sub>2</sub> /H <sub>2</sub> O/H <sub>2</sub> S	DN 1100×2220	1	1
6		20.30m <sup>3</sup>	/		DN 2200×4600	1	1
1		GK355.000 H23079000801		A2 23.4m <sup>2</sup>	400mm	1	1
2		GK356.000 H23079000901		A2			

8	HOLD	HS152.000 ZT22791	A2		1	1	
9	HOLD	/			1	/	
10		TS234.000 ZT22951	A2		1	1	
11		FS745.000 ZT22306	A2		1	1	

### 3.2.3-5

1		3.0m <sup>2</sup>	D	Ø1000×4000	3.4m <sup>3</sup>		1	1	
2			D	Ø273/219×4663	0.12m <sup>3</sup>		10	10	
3		2.1m <sup>2</sup>	D	Ø800/1000×4190	1.52m <sup>3</sup>		2	2	
4			D	Ø600×2000	0.62m <sup>3</sup>		2	2	
5			/				1	/	1
6			D	Ø800×4244	1.58m <sup>3</sup>		1	1	
7		8000×6000×3000	× ×		144m <sup>3</sup>		1	1	
8		8-09N09 D		2900r/min	37kW		2	2	
9		8-09N09 D		2900r/min	37kW		3	2	1
10		×FL-1		1800	1000 ×4000		2	2	
11		×FL-1		1800	1400 ×6000		2	1	1
12		900 754kg/h	800×6000 155		320		2	2	
13		1200 1587kg/h	1200×6000 155		300		2	1	1

14		D	AKL	31.4/		2	2
15		28.6m <sup>2</sup>	700/1400×7000				
16		D	AKL	21.2/		2	2
17		21.2m <sup>2</sup>	700/1400×6000				
18		/		/		2	/
19		16.6m <sup>2</sup>	500/700×4000	92.88×103kJ/h		2	2
20		12.4m <sup>2</sup>	500/700×3000	66.96×103kJ/h		2	2
21		12.4m <sup>2</sup>	500/700×3000	59.76×103kJ/h		/	2
22		/				2	/
23		/				2	/
24		IP55	LHY50-32-160 7.5kW	d CT4		2	2
25		IP55	LHY32-20-250 11kW	d CT4		2	2
26		IP55	SH40-25-250A 5.5kW	API610 d CT4		1	2
27			2100mm	4582mm	14.4		
28		/12.2	m <sup>3</sup>			2	2
29							
30						1	1
31		/				1	/
32		1200×1500mm	V=1.5m <sup>3</sup> 0~5% wt	4mm PO43-		1	1

33			10L/H 4.8MpaG		2	/	2
34		/			2	/	2
35		/			2	/	2
36		/			3	/	3
37		20			2	2	
38		×RQ-1	2		2	1	1

### 3.2.3-6

1		2410×26500	117m <sup>3</sup>		1	1	
2		232m <sup>2</sup>	Ø1300×3000	I DFU 450U	1	1	
3		718m <sup>2</sup>	Ø1600/2500×8200	I DFU 620U	1	1	
4		343m <sup>2</sup>	Ø1200×4050	I CFU 518U	1	1	
5		Ø1400×10904	4100	I 1638m <sup>2</sup>	1	1	
6		1805m <sup>2</sup>	Ø1500×13722	I NEN 2241	1	1	
7		Ø1100×5244	1910	I 428m <sup>2</sup>	1	1	
8		Ø1300/2200×6878	601U	I 662m <sup>2</sup>	1	1	
9		Ø1300/2200×6878	601U	I 662m <sup>2</sup>	1	1	

10		119.3m <sup>2</sup>	II	I	BFU		1	1	
				Ø600×4262	323U				
11		33.2m <sup>2</sup>	II	I	BFU		1	1	
				Ø400×3250	120U				
12		Ø2300×6000			31.62m <sup>3</sup>		1	1	
13		Ø2600×7500			44.83m <sup>3</sup>		1	1	
14		Ø2600×7500			44.83m <sup>3</sup>		/	1	1
15		Ø2400×7000			35.64m <sup>3</sup>		/	1	1
16		0.5MPa		1.0MPa	160		1	1	
		210							
17			II	3.16m <sup>3</sup>	Ø600/1000×9394		1	1	
18		MCZ32-160		YB×5-100L-2WF2/3kW			2	2	
		380V 50Hz 3Phase		d CT4	F				
		IP55		3kW					
19		550×~14120			2500kW		2	2	
20		1200×1500mm			V=1.5m <sup>3</sup>	4mm	1	1	
					0~5%wt PO <sub>4</sub> <sup>3-</sup>				
21					10L/H	4.2MpaG	1	1	
22		BCL405+3BCL405/A			50%		1	1	
					9300kW				
		10000 V/3		1488 rpm	4				

**3.2.3-7**

4		/		1	/	1
5	IV	/		1	/	1
6	III	/		1	/	1
7	II	/		1	/	1
8	I	/		1	/	1
9	I	/		1	/	1
10	A	=395/412m <sup>2</sup> 19×1×6000mm		/	1	1
11	B	=395/412m <sup>2</sup> 19×1×6000mm		/	1	1
12		=395/412m <sup>2</sup> 19×1×6000mm		/	1	1
13	I	3200		1	1	
14	I	/		1	/	1
15	I	ZA150-250 Q=220m <sup>3</sup> /h H=75m D=90kW		2	2	
16	II	3200		1	1	
17	II	/		1	/	1
18	III	850		1	1	
19	III	/		1	/	1
20	III V	/		2	/	2
21		1800		1	1	
22		/		1	/	1
23	V	/		2	/	2
24	V	1800		1	1	
25	V	/		1	/	1
26	V	/		2	/	2
27		2000		1	1	
28		/		1	/	1
29		CZ200-400 Q=400m <sup>3</sup> /h H=33m N=75kW		2	2	
30		20000mm 13000mm =4082m <sup>3</sup>		1	1	
31		/		2	/	2

32		/		1	/	1
33		/		1	/	1
34		/		1	/	1
35		IPSH700-8/0.8	700kg/h 12Pa	1	1	
36		/		1	/	1
37		/		1	/	1
38		/		2	/	2
39		/		1	/	1
40		/		1	/	1
41		/		1	/	1
42		/		1	/	1
43	V	/		2	/	2
44	I	2000mm	3200mm =11m <sup>3</sup>	1	1	
45	I	2400mm	3200mm =11m <sup>3</sup>	1	1	
46		/		1	/	1
47		ZA200-400	Q=400m <sup>3</sup> /h H=36m D=90kW 380V 1491r/min	2	2	
48		4000mm	7320mm =55m <sup>3</sup>	1	1	
49		ZA0250-5400	Q=400m <sup>3</sup> /h H=50m D=185kW	4	2	2
50		6000mm	8200mm =55m <sup>3</sup>	4	1	3
51		HR-800 40T	45kW 90kW	4	5	1
52		/		1	/	1

53	I	/		1	/	1
54		6800×17930 V=482m <sup>3</sup>		1	1	
55		IPSH700-8/0.8 700kg/h 12Pa		2	1	1
56		2EBI303-0 D=11kW		2	2	
57		4000mm 5754mm =55m <sup>3</sup>		1	1	
58		ZA150-315 Q=320m <sup>3</sup> /h H=120m D=220kW		2	2	
59		12-14t/h 3 0.2		1	1	
60		9-19NO11.2D Q=13500m <sup>3</sup> /h P=5500Pa D=75kW		1	1	
61		F=500		1	1	
62		9-19NO 8D Q=7900m <sup>3</sup> /h P=14100Pa D=75kW		1	1	
63		1700 2.2kW		1	1	
64		SH65-50-160A Q=24m <sup>3</sup> /h H=25m D=5.5kW		2	2	
65		2400×3500		1	1	
66		9-26NO10D Q=30200m <sup>3</sup> /h P=3200Pa D=55kW		1	1	
67		×VM32-4 25T D=2 2.0kW		1	1	
68		/		1	/	1
69	II	/		1	/	1
70		120mm 80mm		2	1	1
71		Q=113000kg/h		1	1	
72		;Q=102000kg/h		/	1	1
73		;Q=78400kg/h		/	1	1
74		;Q=68000kg/h		/	1	1
75		;Q=59000kg/h		/	1	1
76		;Q=62000kg/h		/	1	1
77		/		1	2	1
78		/		1	/	1
79		/		1	/	1

80			ZA080-3400 Q=50m <sup>3</sup> /h H=50m D=37kW		2	2		
81			300		2	2		
82	A/B		HR-630 8T	30kW	55kW	2	2	
83	A-E		HR-800 40T	45kW	90kW	/	5	5
84			V=12.5m/s B=1000	L=72.4m	N=18.5kW	1	1	
85			2500mm	5781mm	=16m <sup>3</sup>	1	1	
86			CZ50-200 Q=50m <sup>3</sup> /h H=50m D=22kW			2	2	
87			1500mm	1500mm		1	1	
88			/			1	/	1
89			ZA80-315C Q=87m <sup>3</sup> /h H=105m D=55kW			1	2	1
90			ZA80-315C Q=93m <sup>3</sup> /h H=108m D=75kW			2	2	
91			20000mm	13000mm	=4082m <sup>3</sup>	1	1	
92			CZ250-500C Q=800m <sup>3</sup> /h H=58m D=250kW			1	1	
1	1#	DTII A	Q=25t/h V=1.00m/s B=1000;			1	1	
			L=62m N=11KM					
2	2#		/			1	/	1
3			/			1	/	1
4			/			1	/	1
5			10~60kg/	N=4.0kW		1	1	
6			1250	/	N=90W	1	1	
7			Q=2T			2	1	1
8			Q=2T			1	1	
9			SH65-50-160A Q=24m <sup>3</sup> /h H=25m D=5.5kW			1	2	1
10			2400×3500			1	1	
11			9-26NO10D Q=30200m <sup>3</sup> /h P=3200Pa D=55kW			1	1	
12			Q=2T			3	1	2
13			2T	8.5m		2	1	1



1		18.5kW	6000Nm <sup>3</sup> /hr	NH <sub>3</sub>		4	4	
2		30kW	22000Nm <sup>3</sup> /hr	NH <sub>3</sub>		1	1	
3		3400	18000	145m <sup>3</sup>		1	1	
4		3600	10387	100.8m <sup>3</sup>		4	4	
5	I	280kW	834m <sup>3</sup> /h	70m	plan 54	3	3	
6		30kW	50m <sup>3</sup> /h	62m	plan 54	4	4	
7		18.5kW	60m <sup>3</sup> /h	45m	plan 11	4	8	4
8		5.5kW	15m <sup>3</sup> /h	45m	plan 11	4	8	4
9	I	280kW	834m <sup>3</sup> /h	70m	plan 54	2	2	
10		18.5kW	180m <sup>3</sup> /h	20m	plan 11	2	2	
11		5.5kW	20m <sup>3</sup> /h	25m		1	1	
12		13320×1670mm	2100mm	38.4m <sup>3</sup>		1	1	
13		2000mm	2500mm			4	4	
14		1500mm	2500mm			4	4	
15		3000mm	2500mm			/	4	4
16	I	16400mm	9560mm	1050m <sup>3</sup>		2	2	
17				/		1	/	1
18	I	15000mm	6500mm	1148m <sup>3</sup>		1	1	
19		4600mm	6000mm	99.7m <sup>3</sup>		1	1	
20		1000mm	2000mm	1.8m <sup>3</sup>		4	4	
21		3000mm	3000mm	21.2m <sup>3</sup>		4	4	
22		450mm	1510mm	0.122m <sup>3</sup>		1	1	
23		3400mm	3950mm	46.2m <sup>3</sup>		1	4	3

24		2500×2000mm	2000mm	10m <sup>3</sup>		1	1	
25		33170×8388×4875	55kW	350000	/	0.454kW	4	4
26	1#	Q=400t/h	1.25m/s	37kW		1.5kW	1	1
27		10t	44m	20m/min	7m/min	M4	4	4
		0.8×2kW	13kW					
28	I	/	4kW	0.5r/min	4kW	0.42r/min	2	2
		1.5kW						
1		3400/3000mm	34000mm	258m <sup>3</sup>			1	1
2		2400/2000mm	33731mm	125.3m <sup>3</sup>			1	1
3							1	/
4	II	107	Ø32×0.8 L	4000	273	900mm	2	1
5		600×6000					3	3
6							3	3
7		000×3000					1	1
8		500×6000					3	3
9							2	2
10		1400×3000					1	1
11		/					2	/
12	1#	6355.7	103kJ/h	314m <sup>2</sup>			1	1
13	2#	2149.9	103kJ/h	33.5m <sup>2</sup>			1	1
14		/					1	/
15	II	24500mm	12700mm	2795m <sup>3</sup>			4	4
16		2000mm	2000mm	6.3m <sup>3</sup>			2	1
17	II	12500mm	11000mm	1350m <sup>3</sup>			2	2

18	II	/					1	/	1
19		7000mm	5000mm	192m <sup>3</sup>			1	1	
20		7000mm	5000mm	192m <sup>3</sup>			1	1	
21		/					1	/	1
22		/					1	/	1
23	II	/					1	/	1
24		7000mm	5000mm	192m <sup>3</sup>			1	1	1
25		7000mm	5000mm	192m <sup>3</sup>			1	1	
26		3200mm	4800mm	48m <sup>3</sup>			1	1	
27		7000mm	7000mm	269m <sup>3</sup>			1	1	
28		/					/	1	1
29	II	280kW	850m <sup>3</sup> /h	65m	/	-0.015 /0.724	plan54	3	3
30	II	20m <sup>3</sup> /h	30m	/	0.01/ 0.378	plan54	7.5kW	2	1
31	II	/					2	/	2
32		130m <sup>3</sup> /h	45m	/	-0.006/0.428	plan11	37kW	2	2
33		180m <sup>3</sup> /h	35m	/	0.05/ 0.379	plan21	37kW	2	2
34		180m <sup>3</sup> /h	60m	/	-0.01/0.573	plan11	75kW	2	2
35		70m <sup>3</sup> /h	45m	/	-0.01/0.438	plan11	22kW	2	2
36		80m <sup>3</sup> /h	30m	/	0.06/0.342	plan21	15kW	2	2
37		90m <sup>3</sup> /h	75m	/	-0.01/0.718	plan11	45kW	2	2
38		/					2	/	2
39	II	/					3	/	3
40		/					2	/	2
41		/					2	/	2

42		780m <sup>3</sup> /h	75m	/	-0.01 /0.725	plan11	250kW		3	3	
43		300m <sup>3</sup> /h	50m	/	0.15/ 0.658	plan21	75kW		2	2	
44		2691m <sup>3</sup> /h	15m	/	0.4/ 0.546		160kW		2	2	
45	I	20m <sup>3</sup> /h	25m	/	0/ 0.282		4kW		1	1	
46	II				/				1	/	1
47					/				2	/	1
48	II								4	4	
49						4kW	22r/min		2	1	1
50	II								1	/	1
51	I								8	8	
52	II								10	9	1
53			70mm		2187mm		0.5m <sup>3</sup>		3	2	1
54			4600kW		9.7kW		12	7	2	2	
55									1		1
56		10t	10m	20m/min	7m/min		M4		1	1	
				0.8×2kW	13kW						
1					505m <sup>3</sup> /min				1	2	1
2					1250m <sup>3</sup> /min				2	2	
3			4800mm		15080mm		7662.8m <sup>3</sup>		2	2	
4			4800mm		15080mm		7662.8m <sup>3</sup>		2	2	
5					180				1	1	
6					10.8				2	2	
7					180				1	1	
8			2200mm		5400mm		23.6m <sup>3</sup>		2	2	

9				3000mm	5080mm		1	1	
10	I	242m <sup>3</sup> /h 90kW	70m	/	-0.02/0.65MPaG		2	2	
11	II	169m <sup>3</sup> /h 37kW	45m	/	-0.03/0.41MPaG		2	2	
12		15m <sup>3</sup> /h	25m	/	-0.01/0.26MPaG	4kW	1	1	
13		15m <sup>3</sup> /h	25m	/	-0.01/0.26MPaG	4kW	/	1	1
1	I			1900	6000		3	3	
2				745.4	6000		7	8	1
3	I			800	92		3	3	
4	II			800	94		3	3	
5				100	50		1	1	
6				30	35		1	1	
7				35	65		2	2	
8	I			12500	8500		2	2	
9				/			1	/	1
10				5000×4000×2000	40		1	1	
11				2000×2000×2000	8		/	1	1
12				2000	2000		1	1	
1				20000	55kW		2	2	
2		1800mm	11500mm	27.21	PPR 50		/	1	1
3		610mm	6200mm	1.87	PPR 50		/	1	1
4		2400mm	16827	71	316L 250Y		/	2	2

5		2560	45×6800	3200		12	12	
6			148.5	32×3000		3	3	
7		1100	5			9	9	
8		13500	4	+		12	12	
9		12000	1.45			3	3	
10		180	37			6	6	
11	I	/				4	/	1
12	I	/				4	/	1
13		17m <sup>3</sup> /h	34m	4kW		1	2	1
14		310m <sup>3</sup> /h	48m	75kW		6	6	
15		30m <sup>3</sup> /h	35m	11kW		1	1	
16		/				6	/	6
17		60m <sup>3</sup> /h	45m	15kW		2	4	2
18		250m <sup>3</sup> /h	35m	55kW		3	3	
19		250m <sup>3</sup> /h	33m	55kW		3	3	
20		1000	1500mm	1.48m <sup>3</sup>	1.6m <sup>2</sup>	3	3	
21	1#	2500	7000	41		12	12	
22	2#	1800	3500	10.4		12	12	
23		11500	9000	930		3	3	
24		7350×1900×3300	38.4			3	3	
25		450×1540				12	6	6
26		7000	5711	133.5		3	3	
27	II	/				2	/	2
28	II	22000	9500	2700		2	4	2
29		12000	5000	565		3	3	

30		2500×1500	650/800	2.75		1	1	
31		2200	2200	8.36		1	1	
32		2000×2000×2000		8		2	1	2
33		12000	5000	565		3	3	
34		3000	5000	35		3	3	
35		4050×2150×1977	318LN	45-50	790-950r/min	6	6	
36		930/1012	1500r/min	90kW	1500r/min	55kW		
37	II		2.2	1.9r/min		3	3	
38	II		/			2	/	2
39			0.1r/min	2.2	1.5	2	4	2

5 50\ 00

4

300\ 01\ Q 30

3			/			3	/	2
4			6000	11kW		3	3	
5		3400mm	12774mm	100m <sup>3</sup>	316L	PP 250Y		
6			2400mm	13290mm				
7		3400mm	16434mm	132	316L	PP 250Y		
8			918.96 10 <sup>3</sup> KJ/h	18.45	1682×1140×2276	43		
9			2044	2350×2130×1600				
10			110m <sup>3</sup> /h	42m		30kW		
11			8m <sup>3</sup> /h	60m		5.5kW		
12			85m <sup>3</sup> /h	60m		30kW		
13			100m <sup>3</sup> /h	50m		30kW		
14			50m <sup>3</sup> /h	45m		15kW		
15			10m <sup>3</sup> /h	25m		4kW		
16	1#		1200	1900	2.66			
17	2#		1200	1900	2.66			
18			1200	2200	3			
19			1500	1500	2.65			
20			4000	7000	88			
21	CO <sub>2</sub>		1800	2400	7.6			
22			2000	3000	11.3			
23			/					
24			/					
25			2000×2000×2000	8				
26	1#	71000m <sup>3</sup> /h	560	3	6680×2800×6385mm			

27	2#	0.3						3	3		
28		2925×1300×6350mm						6	4	2	
29		4.18						6	1	5	
30		/						3	/	3	
31		/						3	/	3	
32		5500×3600×6500 50t/h						/	2	2	
33		11000×1700×1600 50t/h						/	3	3	
34		B 400mm H=21.2m 80t/h 0.5m/s 15kW+4kW						6	4	2	
35		260 1.5kW						3	2	1	
36		1200t/d	3600*16500	5000	160kW	18.5	/	1	1		
1		75.1t/h			5820/	6402		1	1		
2		23.52t/h			1600			2	2		
3											1
4											2
5		/						2	/	2	
6		4000	8500	125			2	2			
7		800	1920	1	2.6			1	1		
8		22.5m	18.5m	22.5m	20t	20m/min		1	1		
		4m/min	2.2×2	1.5×2	18.5						
1		12500m <sup>3</sup> /h			110kW			5	5		
2		2000/2400mm	20535mm	76×76×2.8				5	5		
		70m <sup>3</sup>									
3		2800mm	11362mm	50×0.9				5	5		

		65.8m <sup>3</sup>						
4		3158.7×10 <sup>3</sup> kJ/h 2800mm	2590m <sup>2</sup>	32×10000	2607		5	5
5		80m <sup>3</sup> /h 15kW	30m /		-0.015/0.29MPaG		2	2
6		320m <sup>3</sup> /h 45kW	30m /		-0.02/0.28MPaG		2	2
7		450m <sup>3</sup> /h 110kW	50m /		0.03/0.55MPaG		2	2
8			2000mm	3000mm	11.7m <sup>3</sup>		5	5
9			2000mm	3000mm	11.7m <sup>3</sup>		5	5
10			2400mm	3000mm	17.6m <sup>3</sup>		5	5
11			5000mm	5000mm	98m <sup>3</sup>		1	1
12			1800mm	2000mm	6.7m <sup>3</sup>		1	1
13			40m <sup>3</sup>				5	5
14							5	/
15		1000t/d 30kW	3600×30000 37kW	5000m <sup>2</sup> 0.55×4kW	200kW		5	5
16	2#						1	
17			M×820	Q=220t/h	90kW		2	2
18				Q=220t/h	37kW		5	5
19			M×820	Q=220t/h	90kW		5	5
20				55kW			5	5
21			/				1	/
22			/				5	/
23			/				5	/

24			/			1	/	1
25			/			2	/	2
26	20m <sup>3</sup> /h 5.5kW	30m	/	0.006/0.29MPaG		1	1	
27			/			1	/	1
28		2500x						

Εκκ

30 η \ • 409 €



I

350G00

Y

a

9		M×500 Q=160t/h	37kW		2	2	
10		V=0.55m/s	B=600mm Q=160t/h	45+7.5kW	2	2	
11		M×500 Q=160t/h	22kW		2	2	
12		M×500 Q=160t/h	22kW		2	2	
13		MS20 Q=12t/h	7.5kW		1	1	
14		MS40 Q=40t/h	11kW		1	1	
15	M3	5t	20m/min	8m/min	7.2m/min	1	1
			0.8kW	7.5kW			
16		MS20 Q=10t/h	7.5kW		1	1	
17		/			1	/	1
18		Q=5t/h	3kW		1	1	
19		/			2	/	1
20		Q=800t/d	7.5kW		4	4	
21		Q=30t/h	7.5kW		4	4	
22		Q=60t/h	2×11+2.2+0.75kW		4	4	
23		Q=60t/h	2×11+2.2+0.75kW		1	2	2
24		/			1	1	
25		Q=50t/h	7.5 kW		1	2	
26		375m <sup>3</sup> /h	50m	110kW	2	2	
27		30m <sup>3</sup> /h	40m	11kW	2	2	
28		48m <sup>3</sup> /h	45m	15kW	2	2	
29		450m <sup>3</sup> /h	75m	160kW	3	2	
30		20m <sup>3</sup> /h	25m	5.5kW	2	1	1
31	6000	27332kJ/h	600m <sup>2</sup>	25×	4	4	
	1300	1300mm					

32		2200×1800×4958	13.7m <sup>3</sup>		4	4	
33		1400mm	2000mm	3.87m <sup>3</sup>	4	4	
34		2000mm	4000mm	14.8m <sup>3</sup>	4	4	
35		6000mm	5500mm	155m <sup>3</sup>	1	1	
36		4000×2500×11308	91m <sup>3</sup>		1	1	
37		4500mm	4500mm	71m <sup>3</sup>	1	1	
38		n=29rpm	15kW		1	1	
39		3000mm	3720mm	26.3m <sup>3</sup>	1	1	
40		6000mm	6500mm	183.5m <sup>3</sup>	1	1	
41		3172	n=4.46rpm Q=800t/d	55kW	4	4	
42		800t/d	3000×20000mm	2300m <sup>2</sup>	250kW	30kW	
			22kW	0.55×3kW	4	4	
43		F=868m <sup>2</sup>	Q=35000m <sup>3</sup> /h	66.7kW	1	/	
44		F=80m <sup>2</sup>	Q=11500m <sup>3</sup> /h		/	1	1
45		/			8	8	
46		18750kg/h			4	4	
47		/			2	/	2
1		1600mm	25000mm	48m <sup>3</sup>	4	3	1
2		/			1		1
3		48m <sup>3</sup> /h	55m	18.5kW	2	2	
4		/			2	/	2
5		/			2	/	2
6		/			2	/	2
7		/			2	/	2

8			/			2	/	2
9			/			2	/	2
10			/			1	/	1
11			10000mm	10600mm	510m <sup>3</sup>	1	1	
12			/			1	/	1
13			/			1	/	1
14			/			1	/	1
15			/			1	/	1
16			/			1	/	1
17	CN		/			3	/	1
18			/			1	/	1
19			/			1	/	1
20			/			1	/	1
21			/			1	/	1
22			/			1	/	1
23					1680kJ/h	1	1	
24			48m <sup>3</sup> /h	50m		18.5kW	2	2
25			30m <sup>3</sup> /h	70m		18.5kW	2	2
26		Ø4600mm×6618mm		70	S30403	600mm	1	1
				63.6m <sup>3</sup>				
27		Ø4600mm×6618mm		70	S30403	600mm	1	1
				63.6m <sup>3</sup>				
28			800mm	1550mm	0.9m <sup>3</sup>		1	1
29			574/643mm	630mm	7t/h	37kW	2	2
30					1400×1400×1400		1	1

31		48m <sup>3</sup> /h	7.5kW		1	1
32		Frame type	48m <sup>3</sup> /h	15kW	1	1
33		1600×7015	2.9m <sup>3</sup>	30000-35000m <sup>3</sup> /h	1	1
34			30000-35000m <sup>3</sup> /h	<1500pa	1	1
35		Q=9500m <sup>3</sup> /h	0.025×15=0.375kW;	1.5kW;	1	1
36			1200×33304		1	1
37		250×12000	8/h	4kW	1	1
38			/		1	/
39			/		1	/
40		2142×1741	7t/h	5.5kW	1	1
41			300×380		1	1
42			/		1	/
43			/		1	/
44			/		1	/
45			/		1	/
46			/		1	/
47			/		1	/
48			/		1	/
49			/		1	/

### 3.3

3.3-1

#### 3.3-1

**t/a**  
676576

**t/a**  
657490.

**t**

### 3.4

“	+AO	”	160t/h				
							826.2t/h
3.09t/h		315.06t/h		8535.77t/h		2777.16t/h	
12771.24t/h		3297.85t/h	131.78t/h		3.4-1		

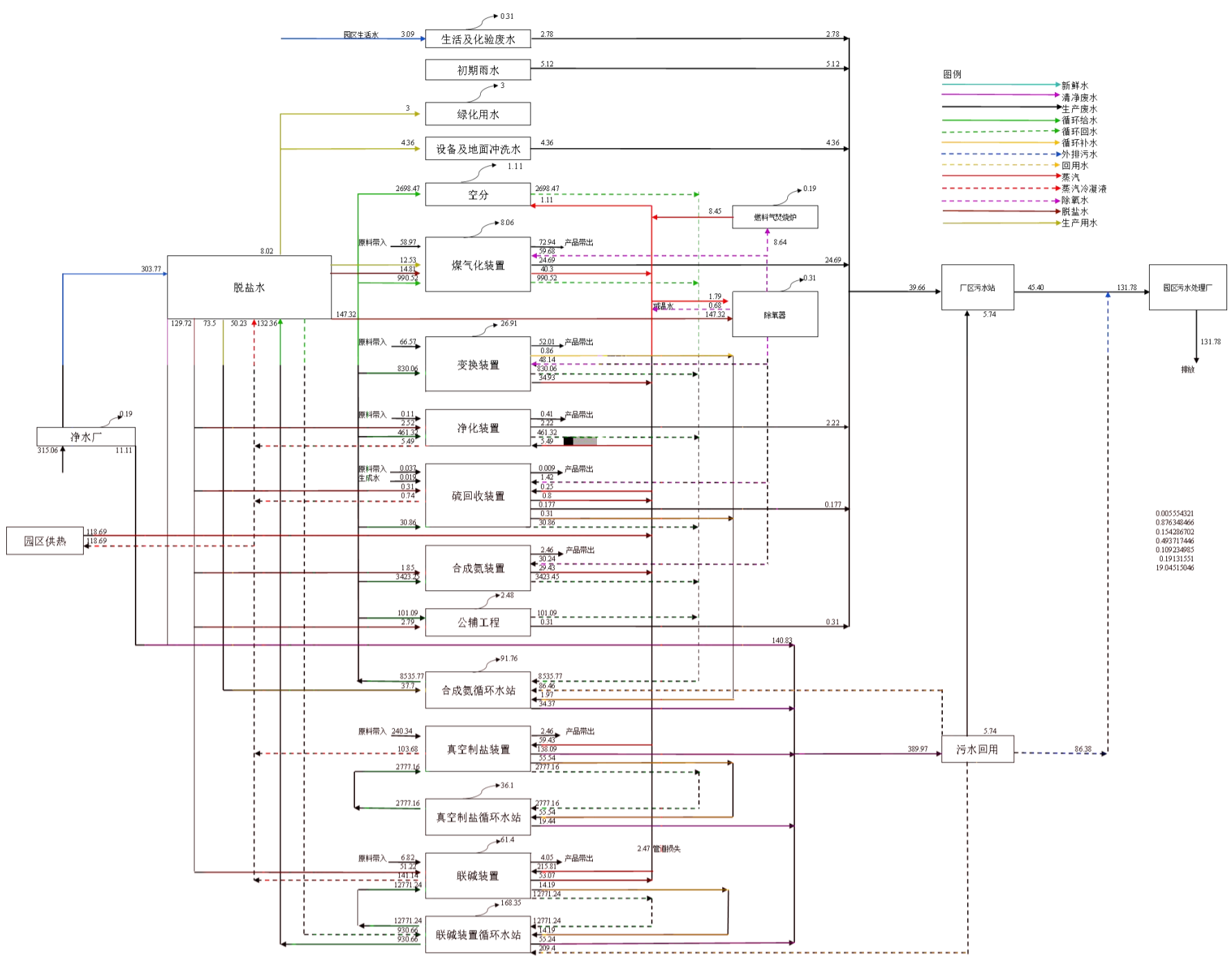

### 3.5

CO H<sub>2</sub> CO<sub>2</sub>  
CO H<sub>2</sub>O H<sub>2</sub> CO<sub>2</sub>  
CO<sub>2</sub> H<sub>2</sub>S

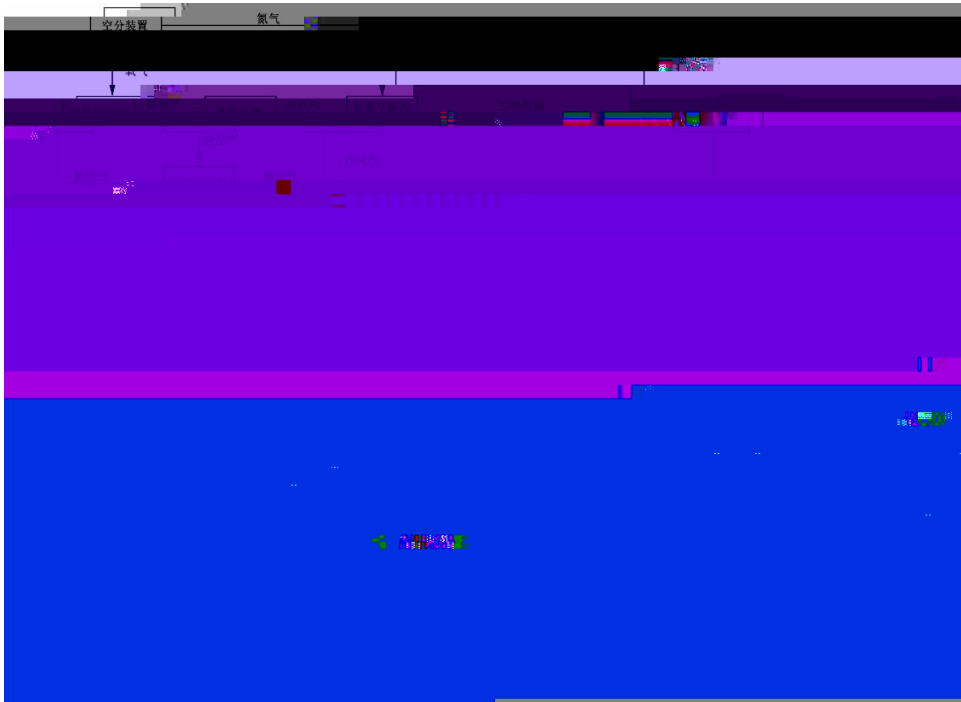

3.5-1

### 3.5.1

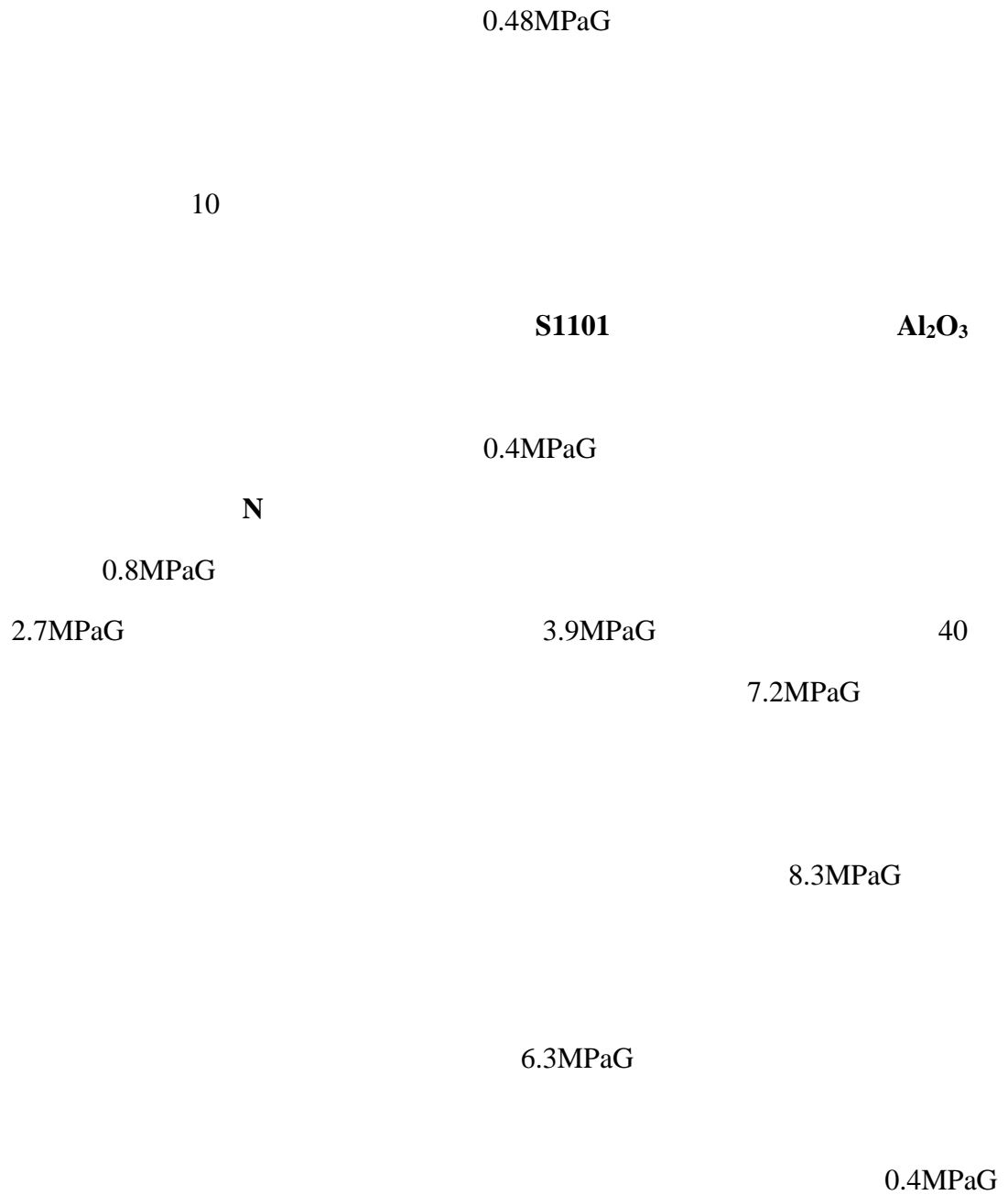

0.8MPaG

G1101

12.3MPaG

8.3MPaG

3.5.1-1

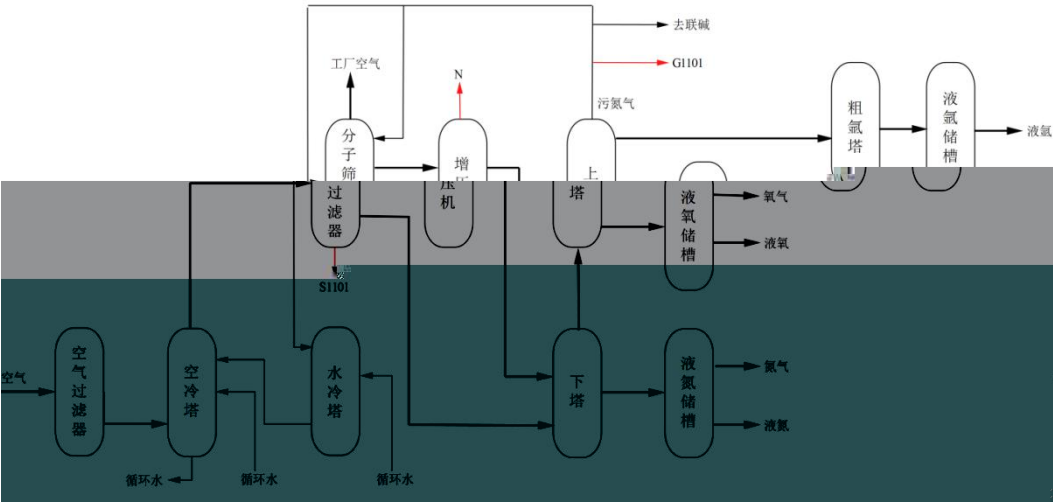

3.5.1-1

3.5.2

20mm

223 6.3MPaG

3.2MPaG

285 8.2MPaG

3

173.3 0.8MPaG

173.3 0.8MPaG

132 0.2MPaG

69 -0.07MPaG

**G2301**

**H<sub>2</sub>S**

**W2101**

**CODcr SS**

127 0.15MPaG

**S2102**

3.5.2-1

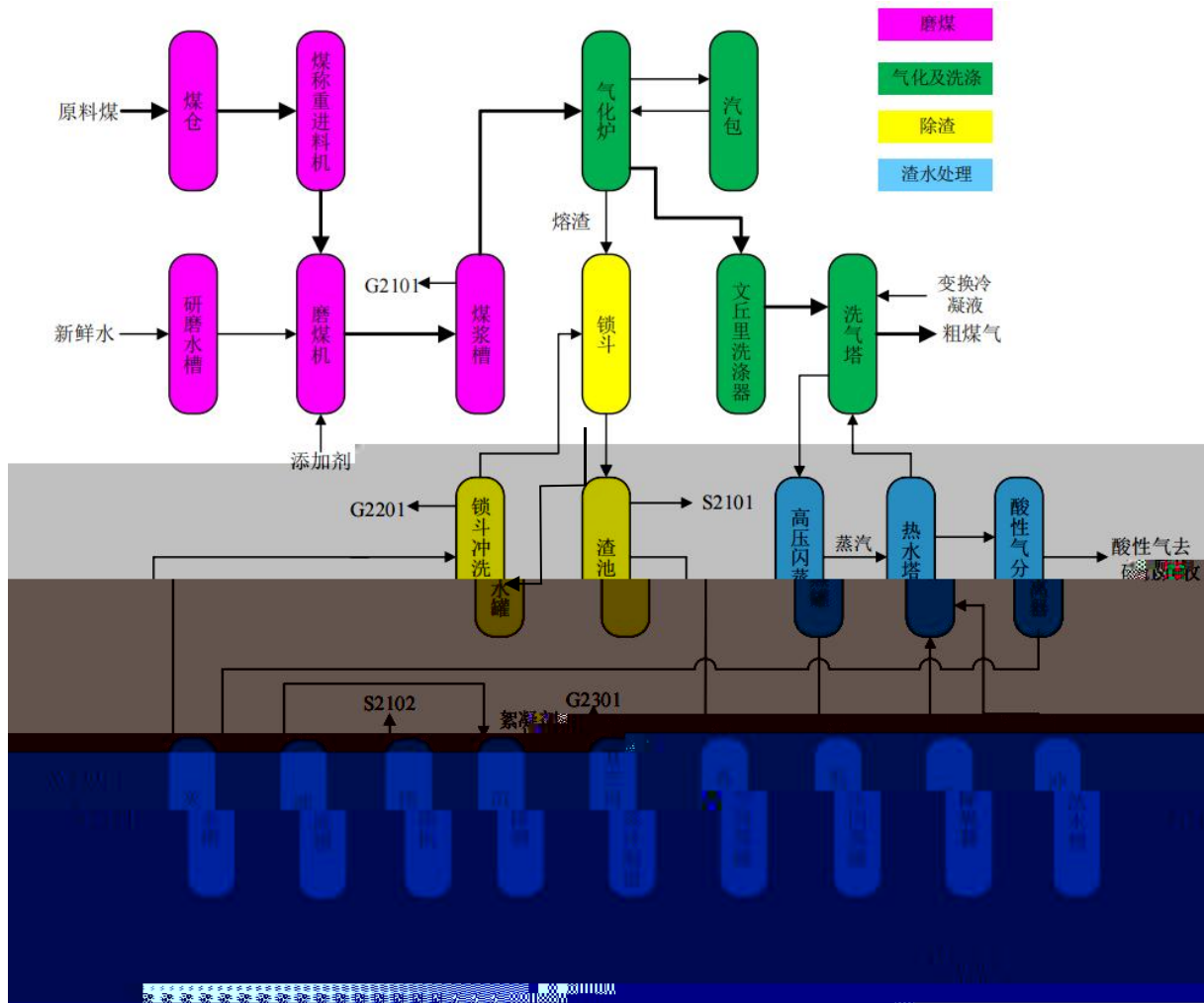

3.5.2-1

### 3.5.3

	CO	H <sub>2</sub> O	H <sub>2</sub>	CO <sub>2</sub>	CO	H <sub>2</sub>
	$\text{CO} + \text{H}_2\text{O} = \text{CO}_2 + \text{H}_2$					
	6.30MPaG 224					
	~260		A/B		_S3101	
	Al <sub>2</sub> O <sub>3</sub>		1#		1#	
	3.2MPaG 1#		~300			
	~262				142	
	247 2#		CO		1.0% 2#	
	1.6MPaG 2#		227		165	

0.5MPaG

40

1# 2#

S3102 S3103

Co Mo

0.33MPG

0.5MPaG

0.5MPaG

40

155

1#

2#

3.5.3-1

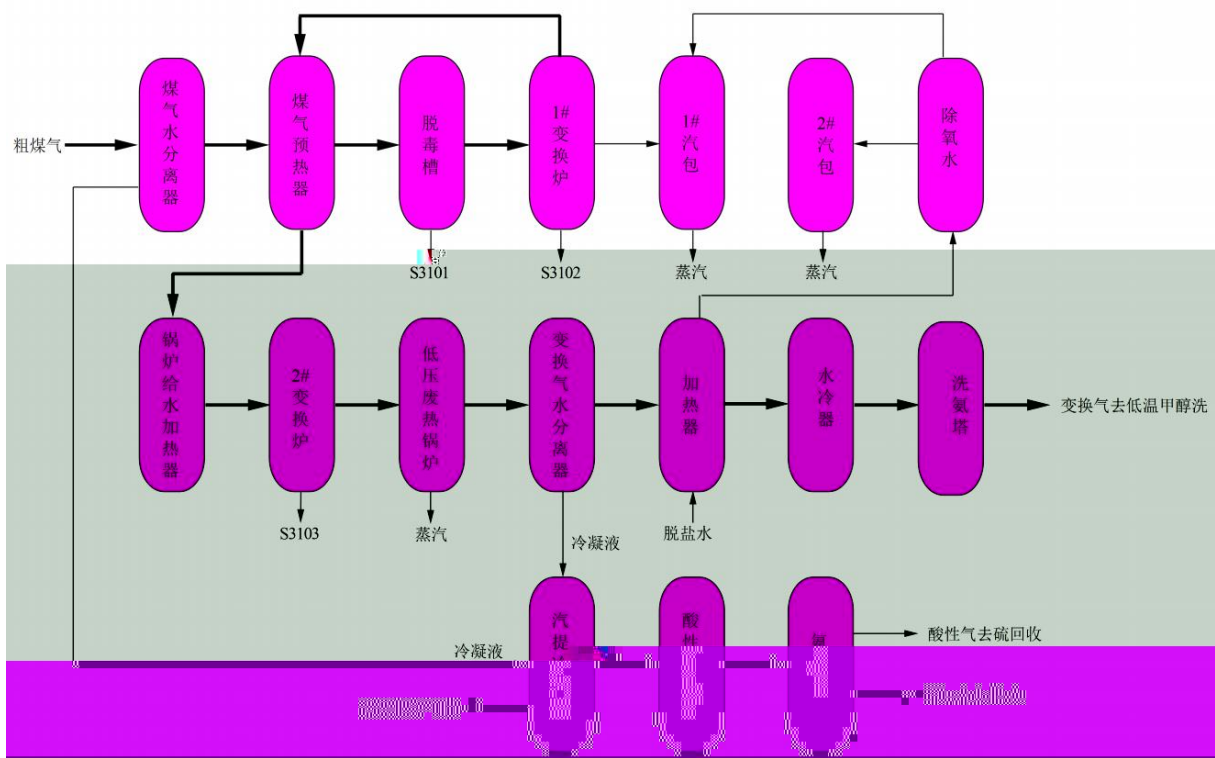

3.5.3-1

### 3.5.4

1

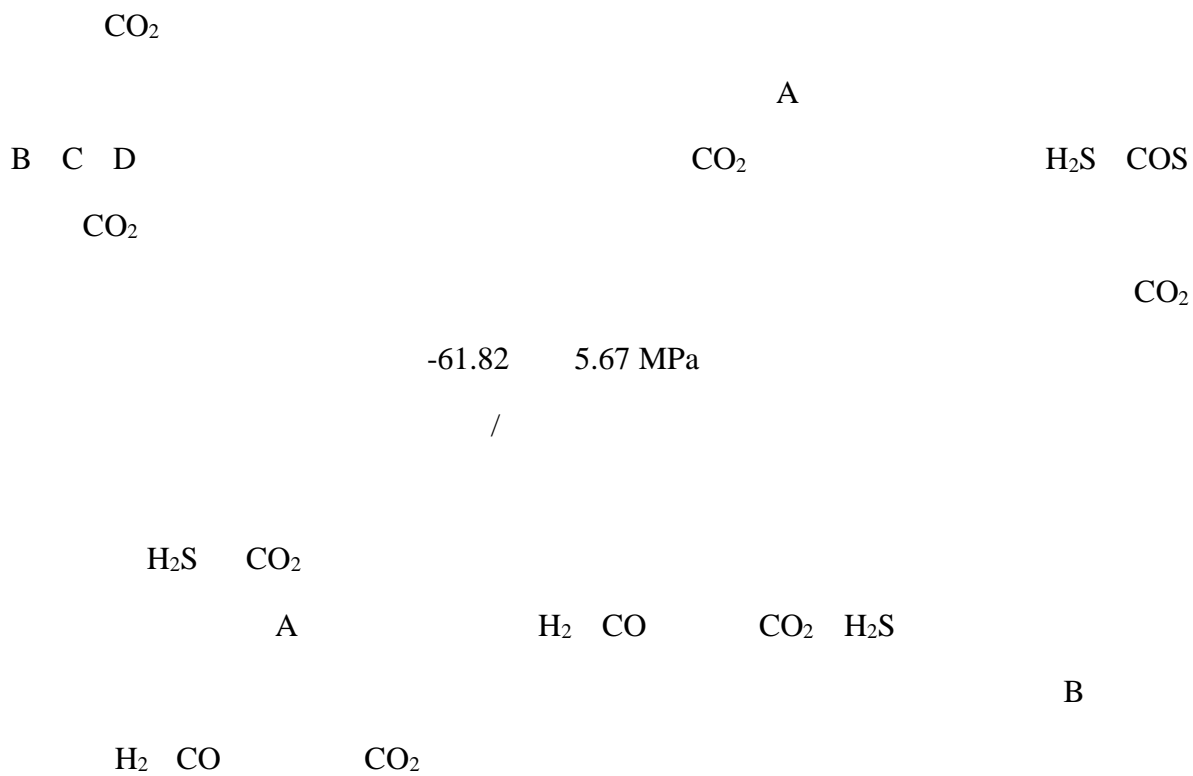

C-101

	A		CO <sub>2</sub>	C	
CO <sub>2</sub>	H <sub>2</sub> S			B	
	CO <sub>2</sub>	D	CO <sub>2</sub>	H <sub>2</sub> S	C
	CO <sub>2</sub>	C		A	
	CO <sub>2</sub>		CO <sub>2</sub>	CO <sub>2</sub> /	
		30	0.24MPa		
	C				
D			H <sub>2</sub> S	B	
	H <sub>2</sub> S			18.37	0.12MPa 2#

**G4101**

CO <sub>2</sub>	C	H <sub>2</sub> S	B		H <sub>2</sub> S	B
			3#			
					CO <sub>2</sub>	A
CO <sub>2</sub>		CO <sub>2</sub>	B	2#		
		CO <sub>2</sub>	B		CO <sub>2</sub>	CO <sub>2</sub> B
H <sub>2</sub> S	A				H <sub>2</sub> S	CO <sub>2</sub>
				CO <sub>2</sub>		
			B			3#
		1#				
					CO <sub>2</sub>	
H <sub>2</sub> S						4#
						1#
2#						
	3#					

H<sub>2</sub>S  
 H<sub>2</sub>S  
 37.55 0.25MPa  
 H<sub>2</sub>S  
 H<sub>2</sub>S H<sub>2</sub>S  
 /CO<sub>2</sub> CO<sub>2</sub> /  
 H<sub>2</sub>S  
 /  
**W4101**  
 3  
 -60.9 5.52MPaG  
**S4101** CO<sub>2</sub> CH<sub>3</sub>OH H<sub>2</sub>O 1#  
 2#  
 CO CH<sub>4</sub> Ar  
 2# 1#  
 40 6.2MPaG 1#  
 2#  
 1700kPa 2#  
 1#  
 420kPa 2# 1#  
 30  
 3.5.4-1

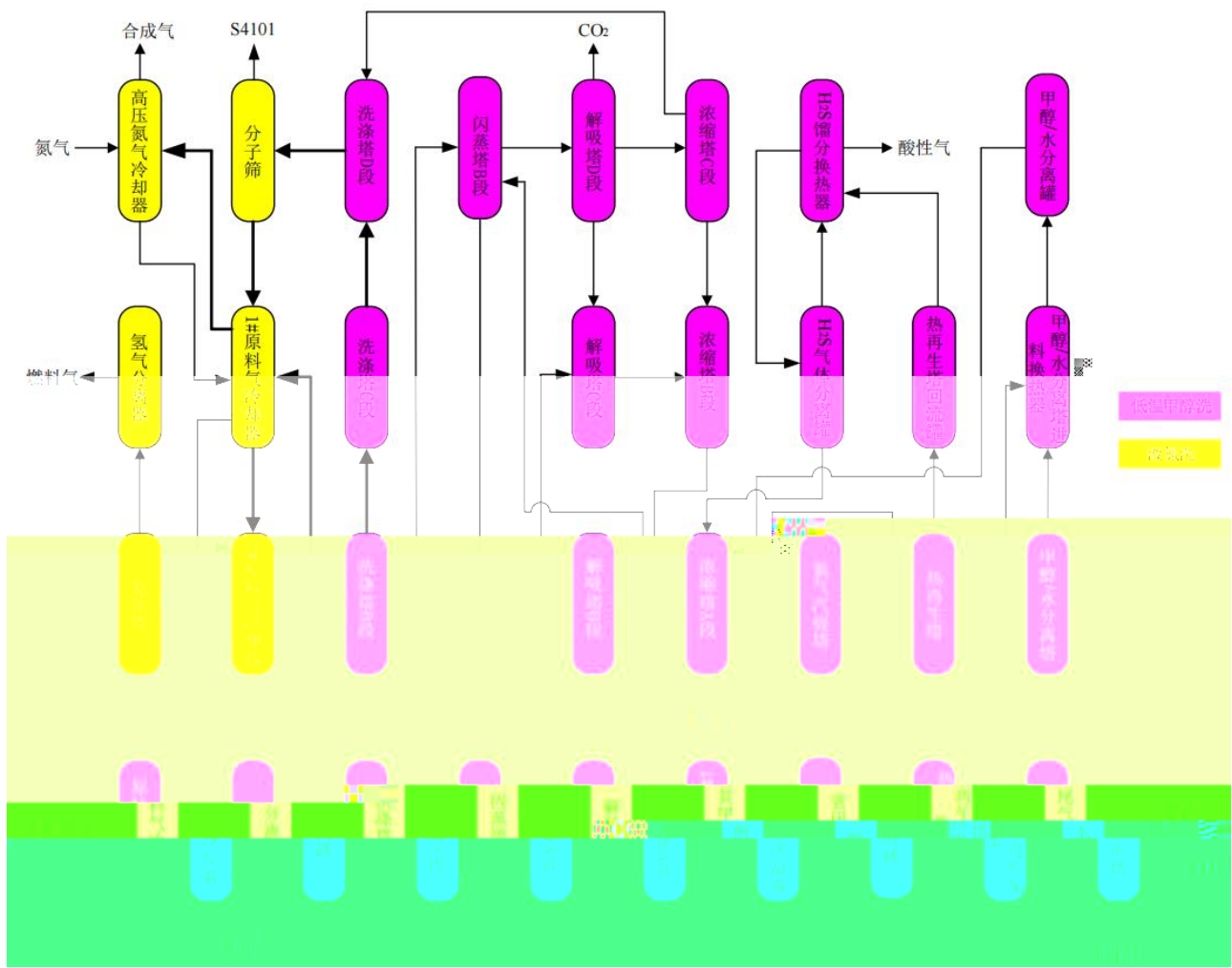

3.5.4-1



2

				H <sub>2</sub> S	H <sub>2</sub> S
SO <sub>2</sub>	CO <sub>2</sub>	H <sub>2</sub> O			

3

<b>_G5201</b>		50	/
	2	/	

4

	66	
SO <sub>2</sub>		<b>_G5101</b>
SO <sub>2</sub> H <sub>2</sub> S NO <sub>x</sub>		100mg/Nm <sup>3</sup>
7%		

<b>_W5101</b>	<b>COD TDS</b>
	3.5.5-1

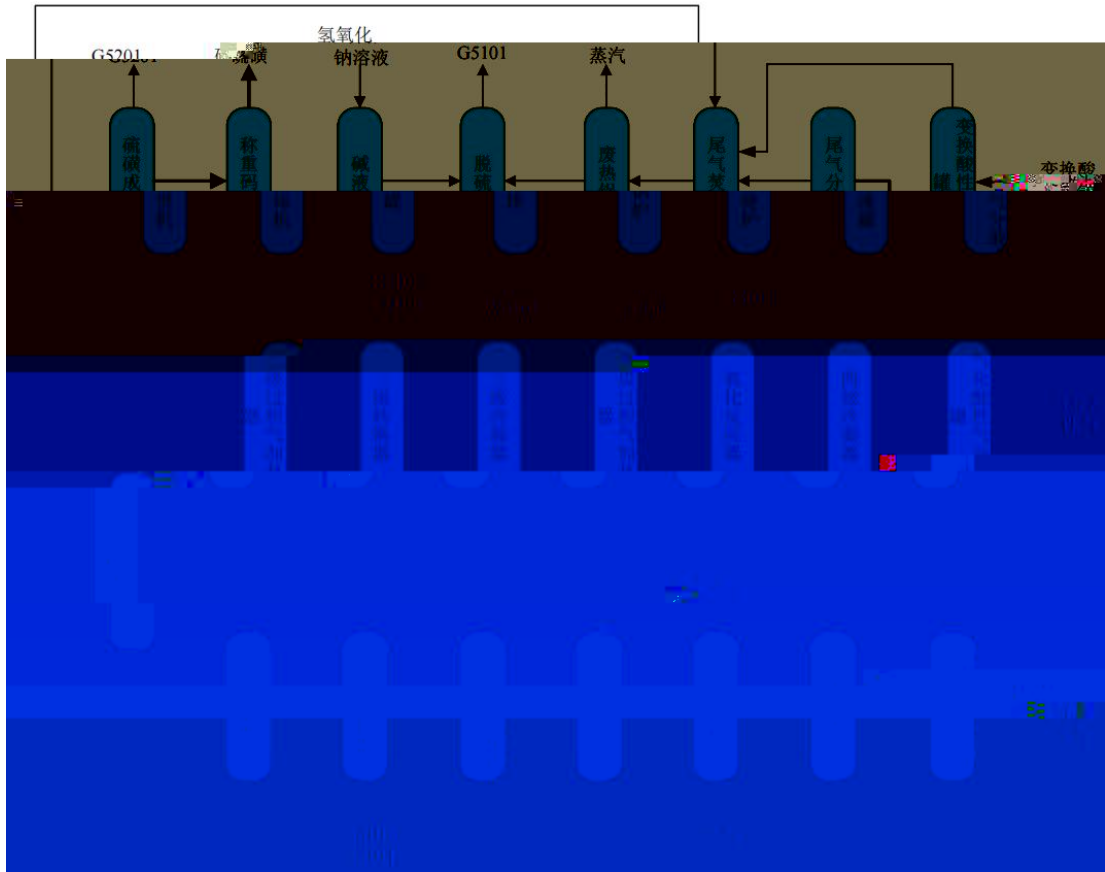

3.5.5-1

### 3.5.6

1

13.13MPaG

14.35MPaG

2

1

1

180 200

2

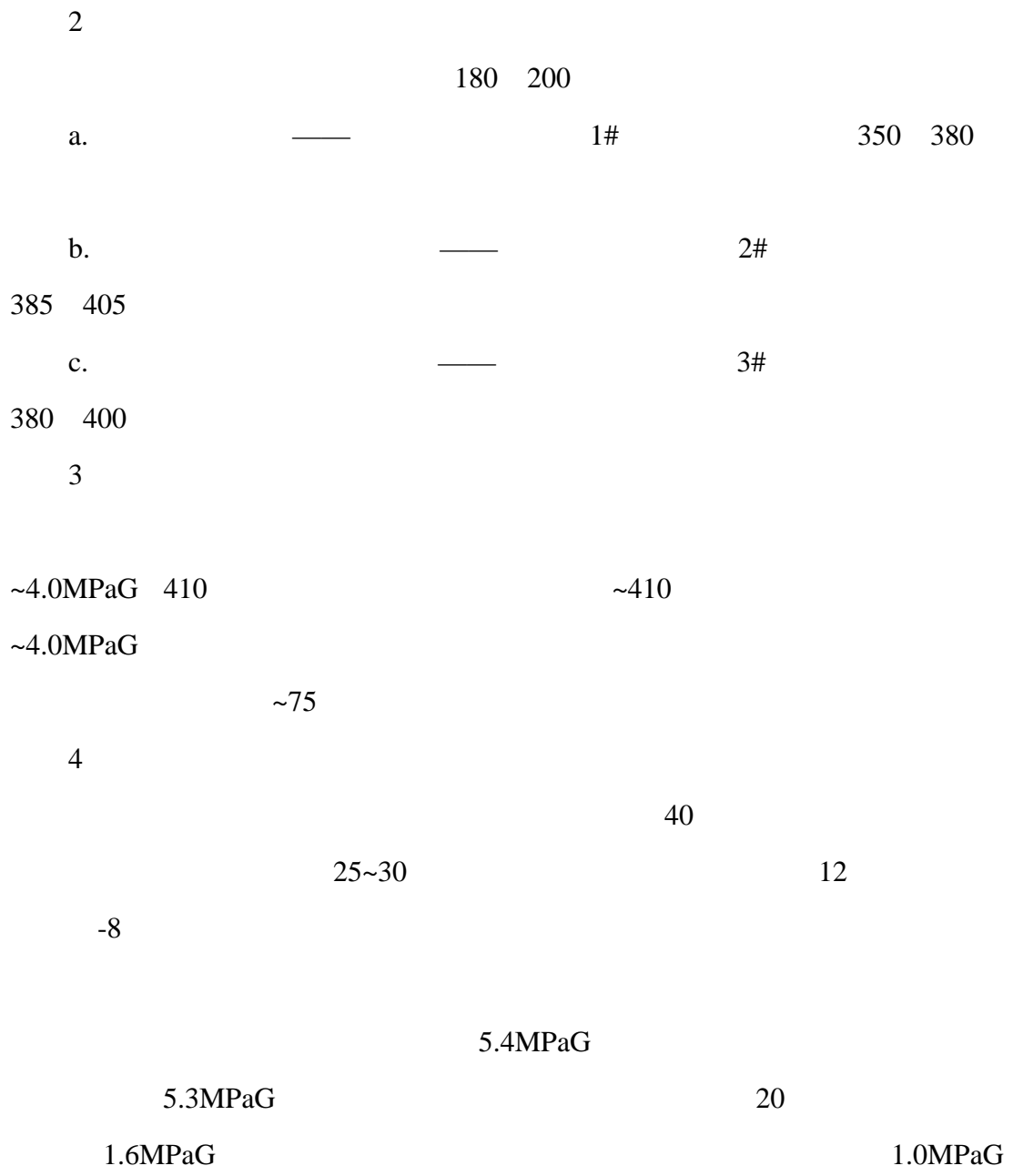

5

3

-38                    0.060MPa   A

-8                    0.26MPa   A

11                    0.59MPa   A

40                    1.71MPaA

5

3.5.6-1

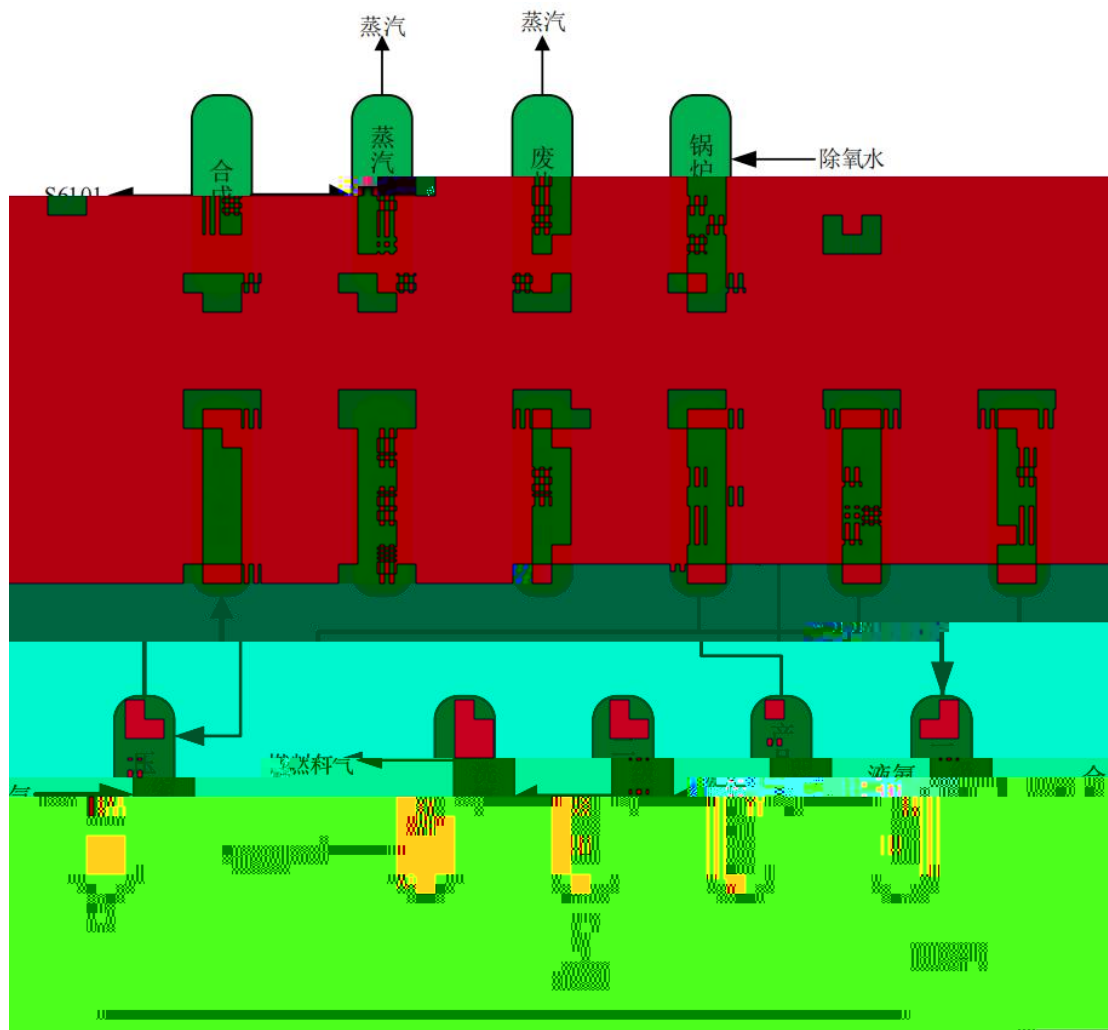

3.5.6-1

### 3.5.7

1

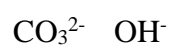
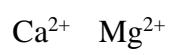

4544

\_S7101

2

65g/L

**\_G7101**

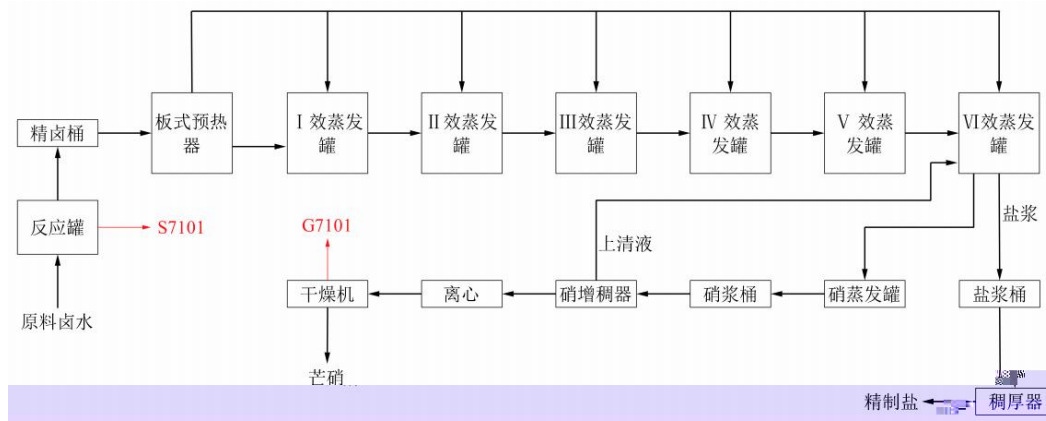

**3.5.7-1**

**3.5.8**

1

I

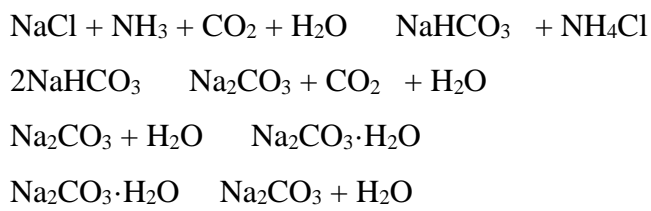

3.5.8-1

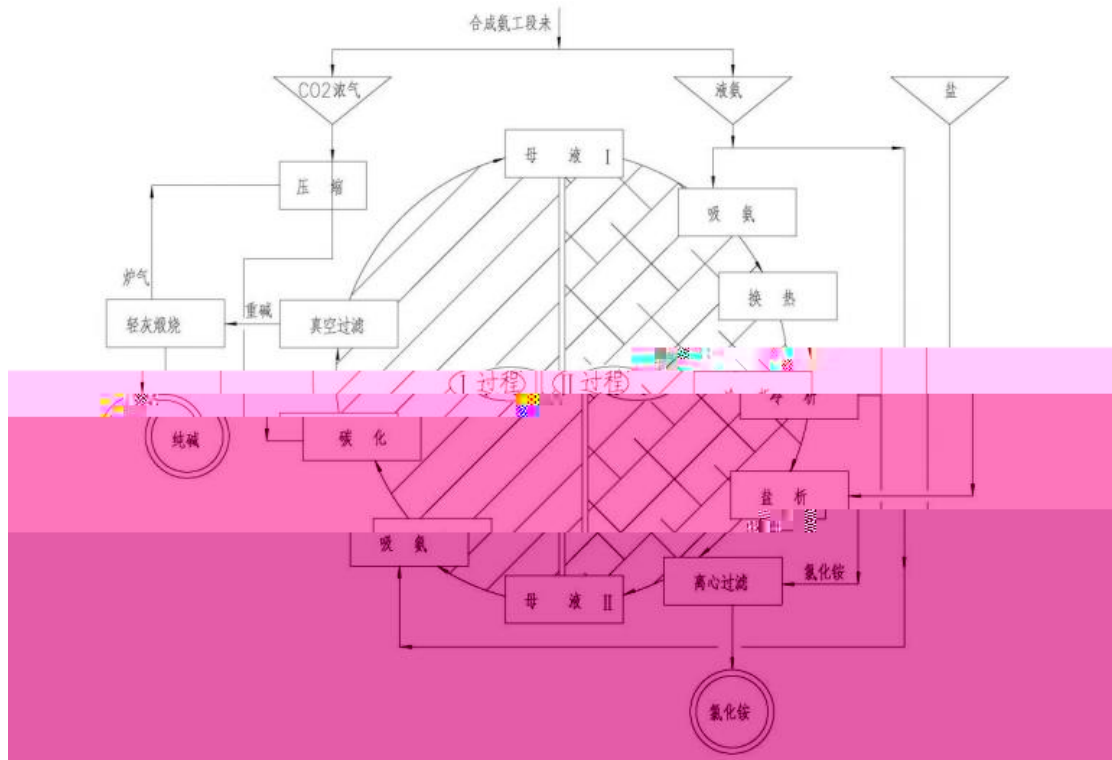

3.5.8-1

2

1

40 0.59MPaG

40 0.55MPaG

40

0.40MPaG

25 0.40MPaG

NH<sub>3</sub> CO<sub>2</sub>

\_G8101

NH<sub>3</sub>

40 0.50MPaG

40 0.59MPaG

I

I

32 0.55MPaG

2

I

I

M

I

40

0.80MPaG

35 -0.06MPaG

**\_G8301**

**NH<sub>3</sub>**

3

NH<sub>3</sub>

159 0.5MPaG

NH<sub>3</sub>



20 0.50MPaG

Ca<sup>2+</sup> Mg<sup>2+</sup>

β

II

II



159 0.5MPaG

4

È

40

227 0.48-0.53MPaG

41 0.48-0.53MPaG

34-40 35KPaA

190-203 0.05MPaG

45 0.05MPaG

30

		26.4	0.4MPaG		
26	0.4MPaG				
	9.5	0.026MPaG		15	0.06MPaG
				12	
	6.8	0.45MPaG			
				10	
		10		10	
				15	
				15	0.08MPaG
		15	0.11MPaG		
	15				
	10				
		10			
				10	
	10				
52	0.14MPaG				
		40	1.45MPaG		
				-4	1.6MPaG
	6.8	0.45MPaG		6.8	0.45MPaG
					6.8

0.45MPaG

I

24

0.45MPaG

I

**\_G8401**

**NH<sub>3</sub>**

25

0.4MPaG

25

0.5MPaG

7

10

1.6MPaG 205

90

-0.001MPaG

35

1.6MPaG

170

1.6MPaG

0.5MPaG 158

110

60

0.5%

**\_G8601**

8

0-6.8

0.33MPaG

104

1.62MPaG

70

1.59MPaG

40

1.45MPaG

0-6.8

0.33MPaG

70

1.56MPaG

40

1.45MPaG

40

1.45MPaG

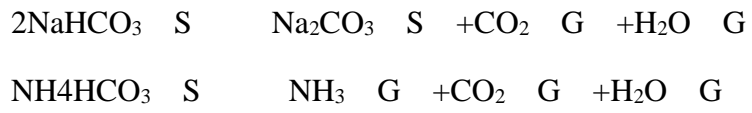

30

3.1MPaG 287

180

1.6MpaG

0.5MPaG

115 -0.001MPaG

85 0.5MPaG

40

40 0.001MPaG

**\_G8501****NH<sub>3</sub>**

40 0.3MPaG

10

170~190

80

160

80

**\_G8702**

**\_G8701**

1.6MPa

0.5MPaG

2

1

40 0.3MPaG

80 0.2MPaG

80 0.4MPaG

80 0.4MPaG PE

80 0.3MPaG

80 0.0MPaG

40 0.4MPaG

NaHCO<sub>3</sub>

NaHCO<sub>3</sub>

PE

2

NaHCO<sub>3</sub> 72 0.2MPaG

72 0.0MPaG

80 0.0MPaG

40 0.0MPaG

80 0.0MPaG

+

**\_G8802**

25 0.3MPaG

40 0.0MPaG

**\_G8801**

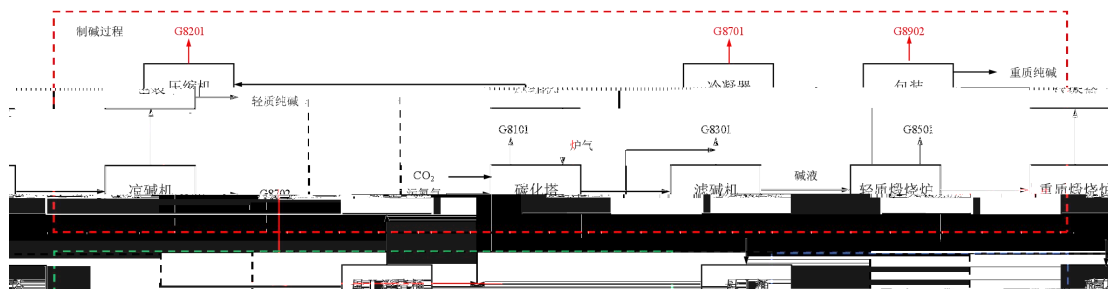

3.5.8-2

3.6

2018 6 4

3.6-1

3.6-1

	30%		



3.6-2

1.			/
2.	30%	<p>110 / 30 / 110 / 80 / 45000Nm3/</p> <p>40 / 100 /</p> <p>6.5 / 5.4 /</p> <p>2.2 / 1.2 / 4.8 /</p> <p>4800 / 1.6 /</p> <p>2×2475 / 2×2500 /</p> <p>30%</p>	<p>110 / 30 / 110</p> <p>40 / 100</p> <p>6.5 / 2.2</p> <p>5.4 / 4.8</p> <p>1.2 / 1.6</p>
3.		1960256t/a COD SS	1960256t/a
4.	10%	<p>PM<sub>2.5</sub></p> <p>SO<sub>2</sub> NO<sub>x</sub></p> <p>VOCs COD SS</p> <p>TDS</p>	<p>2×2475 / 2×2500 /</p>
5.			6.1.2

200m

200m

6.

1

2

3

4

10%

7.

10%

8.

6

10%



		826.2t/h					
		GB18918-2002 A					
		DB32/939-2020 2					
		3 4					
9.			GB18918-2002				
		A					
		DB32/939-2020 2 3 4					
10.							
	10%		60m			64m	
11.							
12.							/
13.							
		1	4	2800m <sup>3</sup>	467m <sup>3</sup>	4	
				4	541.4m <sup>3</sup>	1	3080m <sup>3</sup>

		380m <sup>3</sup> 1	6
	3000m <sup>3</sup> 2		812.1m <sup>3</sup> 1
	12000m <sup>3</sup>		3830m <sup>3</sup>
	7400m <sup>3</sup>		2
			13376m <sup>3</sup>
			7400m <sup>3</sup>

# 4

## 4.1

W2101\_

W4101\_

W5101\_

GB 13458-2013

GB18918-2002 A

DB32/939-2020 2 3 4

GB/T 19923-2024

GB/T 50050-2017

“ +AO ” 160t/h

826.2t/h

4.1-1

4.1-1

4.1-2

4.1-1

			t/h	t/h	t/h	t/h				
		COD SS	40	24.69	/	24.69				
		COD SS	3.59	2.22	/	2.22				
		COD	0.56	0.177	/	0.177				
		COD SS	10	4.36	/	4.36				
		COD SS	4.5	2.78	/	2.78				
		COD TDS	1.41	0.31	/	0.31				
		COD			/					
		COD SS TDS			/					
		COD SS	4.12	5.12	/	5.12				
		COD SS TDS	9.3	5.74	389.97	5.74				
		COD SS TDS	140.05	86.38	389.97	86.38				
		COD SS TDS	18	11.11	/	/				
		COD SS TDS	210.2	129.72	/	/				

			t/h	t/h	t/h	t/h				
		COD SS TDS	55.7	34.37	86.46	/				
		COD SS TDS	89.5	55.24	209.4	/				
		COD SS TDS	223.75	138.09	/	/				
		COD SS TDS	31.5	19.44	/	/				

4.1-2

		mg/L	mg/L
	COD	244.2093	44.625
	SS	143.4153	18
		13.7651	3.93
		24.0888	0.40
		0.0714	37.1
		0.0937	0.011
		0.0099	ND
		0.1873	ND
		5.0511	ND
		9.9816	0.12
	TDS	4768.7466	1056.5
		mg/L	mg/L
	COD	14.3669	11.625
	SS	4.8146	6.375
	TDS	87.197	41.75

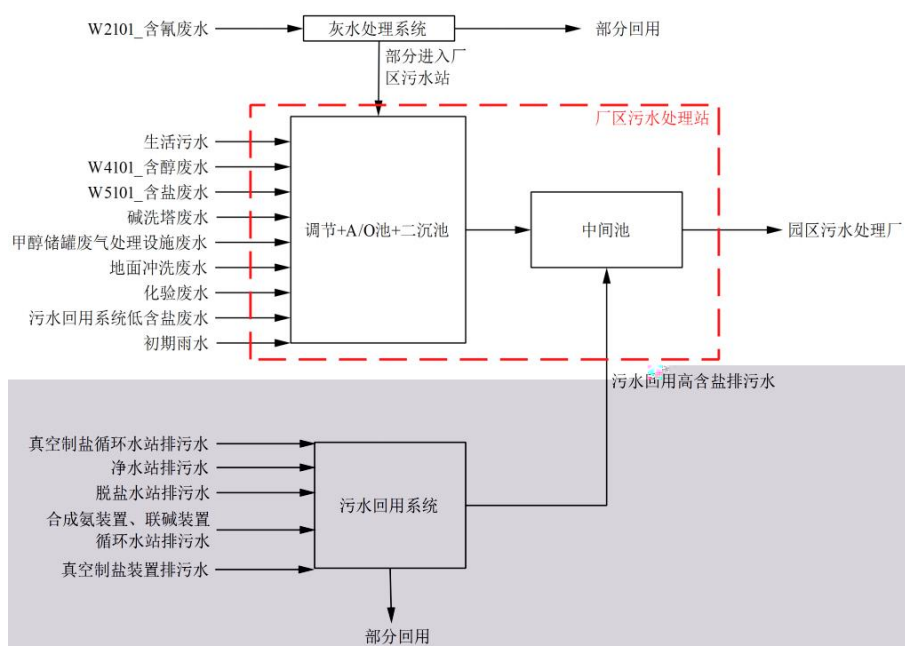

4.1--

é

C



	/	/
	/	/

## 4.2

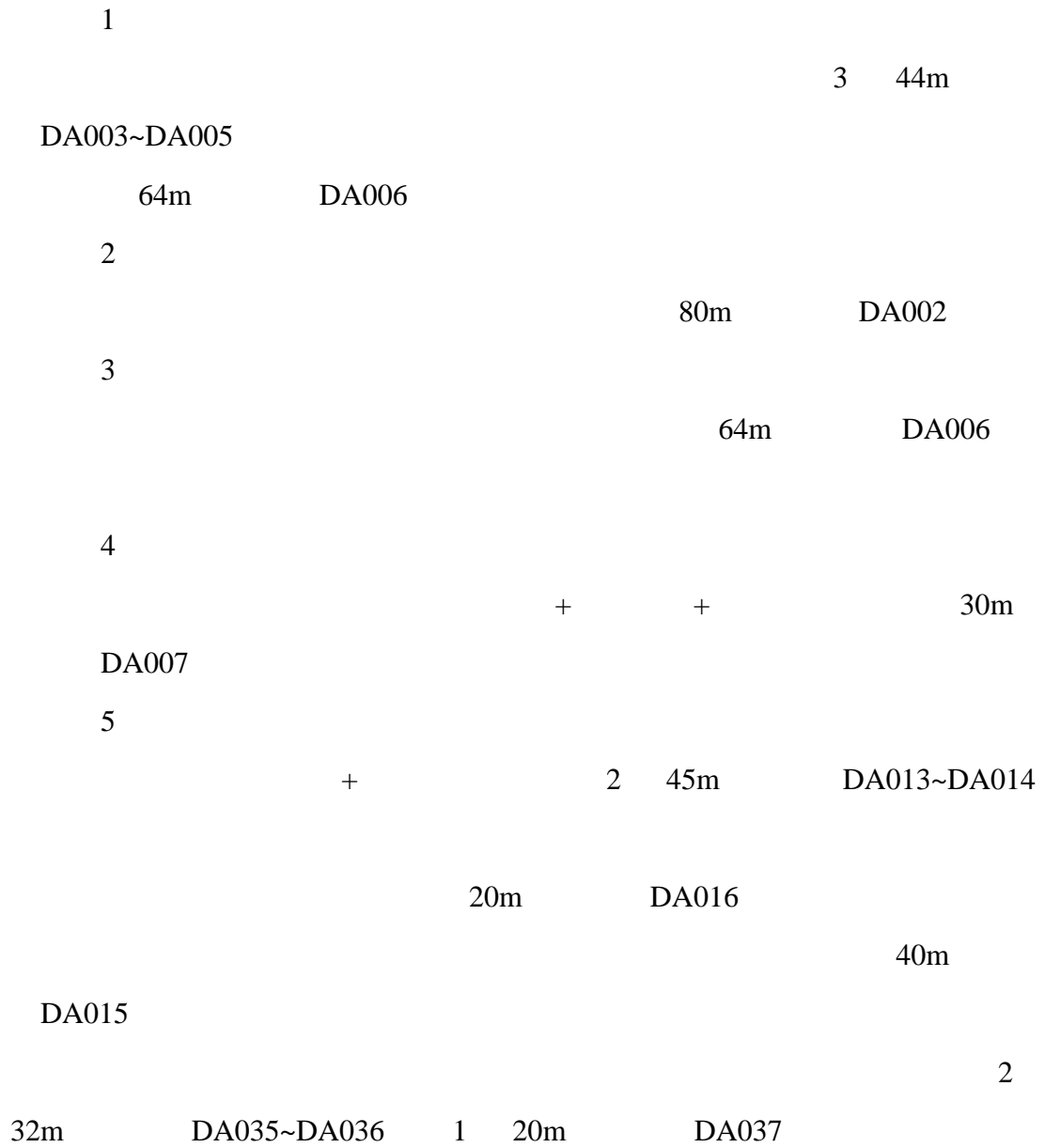

			+	+	20m
DA011					
		3	24m	DA017~DA019	
				36m	DA012
		2	36m	DA020~DA021	2
30m	DA030~DA031				
			+	20m	DA022
				20m	DA034
		2	30m	DA032~DA033	
6					
			15m	DA038	
1#			32m	DA008	
2#			33m	DA009	
3#			49m	DA010	
			21m	DA023	
1#			45m	DA024	
2#			45m	DA025	
3#			45m	DA026	
		1		15m	DA027
		2		15m	DA028
		3		15m	DA029
7					
					+
15m	DA054				

8

15m

DA039

9

15m

DA040

10

+

13 17m

DA041~DA53

11

NOx

SCR

15m

4.2-1

				<b>m<sup>3</sup>/h</b>	<b>m</b>	<b>m</b>			
			DA003	15000	44	0.8			
			DA004	15000	44	0.8			
			DA005	15000	44	0.7			
		NO <sub>x</sub>	DA006	600	64	0.15	+		
				2944					
		NMHC	DA002	44657	80	1.2			
			DA007	17300	30	1	+	+	+
								+	
		NH <sub>3</sub>	DA013	11000	45	0.4	+		
		NH <sub>3</sub>	DA014	11000	45	0.4	+		
		NH <sub>3</sub>	DA016	44960	20	1			
		NH <sub>3</sub>	DA015	18860	40	1			
		NH <sub>3</sub>	DA035	9251	32	0.7			
		NH <sub>3</sub>	DA036	9251	32	0.7			
		NH <sub>3</sub>	DA037	1000	20	0.15	+		

				<b>m<sup>3</sup>/h</b>	<b>m</b>	<b>m</b>					
		NH <sub>3</sub>	DA011	10260	20	0.7	+	+			
			DA017	12000	24	0.4					
			DA018	11000	24	0.4					
			DA019	11000	24	0.4	/				
			DA012	36000	36	1.2					
			DA020	11000	36	0.5		/	/		
			DA021	10000	36	0.5					
			DA034	6053	20	0.5		+	+		
			DA022	6000	20	0.8	/				
			DA032	21000	20	0.9					
			DA033	21000	20	1					
			DA031	27000	30	0.7					
			DA030	27000	30	0.6					
			DA038	8200	15	0.42	/				
	1#		DA008	21000	32	0.7					
	2#		DA009	27000	33	1					
	3#		DA010	11000	49	0.7					
			DA023	11000	21	0.7					

1#

D





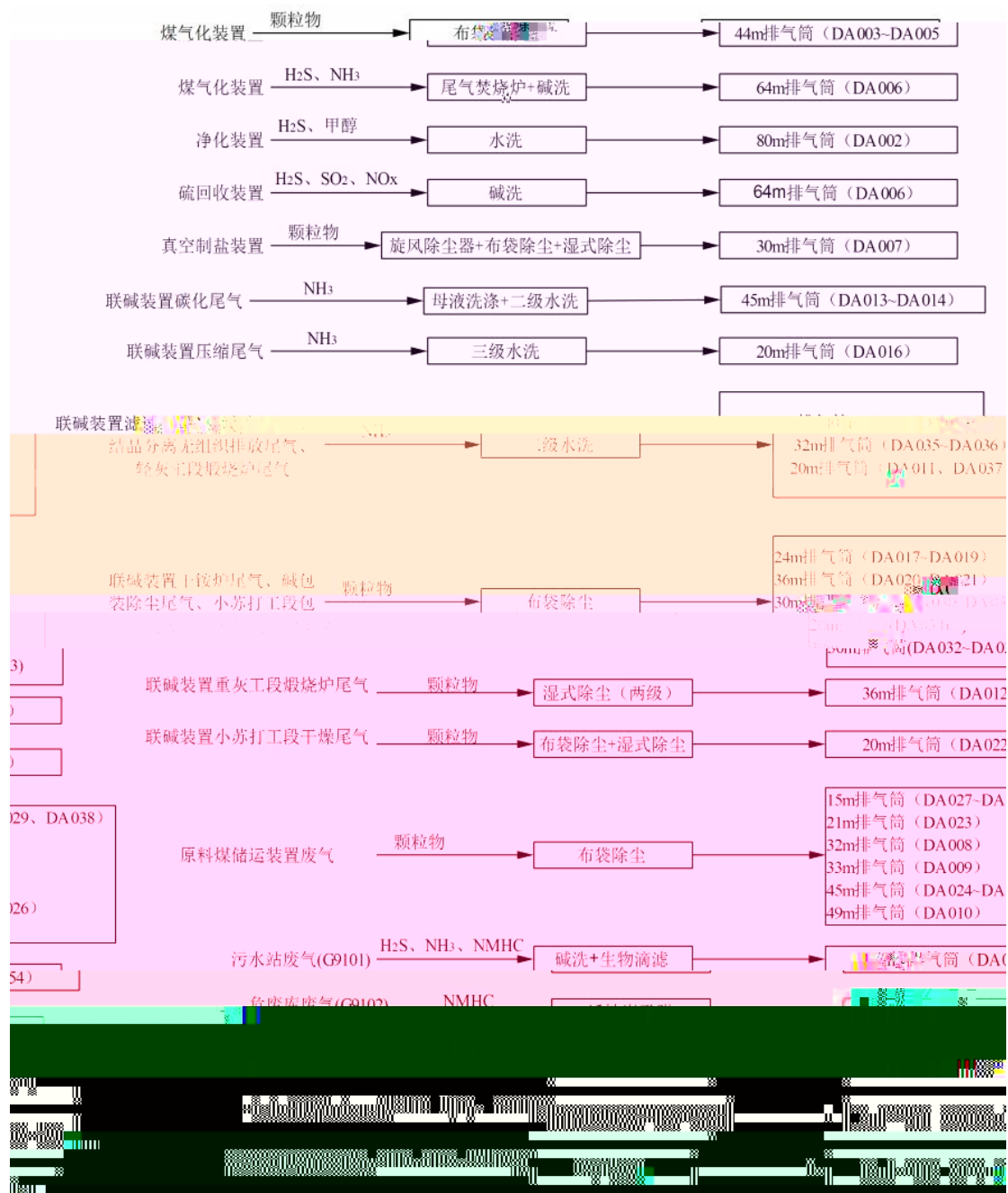

$m^3/h$  m m

				<b>m<sup>3</sup>/h</b>	<b>m</b>	<b>m</b>					
			DA046	1500	17	0.6	/	+	+		
			DA047	1500	17	0.6	/	+	+		
			DA048	1000	17	0.35	/	+	+		
			DA049	1000	17	0.35	/	+	+		
			DA050	880	17	0.25	/	+	+		
			DA051	880	17	0.25	/	+	+		
			DA052	880	17	0.25	/	+	+		
			DA053	880	17	0.25	/	+	+		



4.2-1

VOCs

	
<p>SCR</p>	<p>DA001</p>
	
	<p>DA002</p>
	
	<p>DA003</p>









DA004



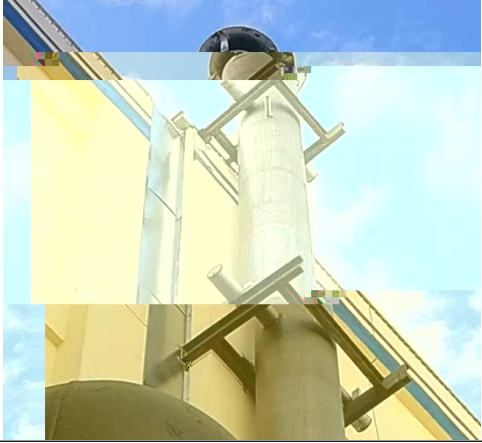

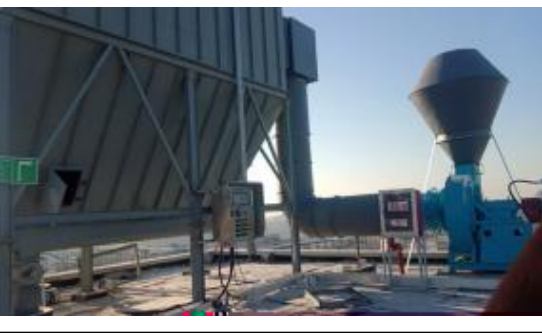

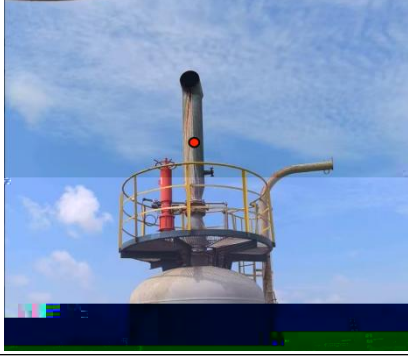

DA005

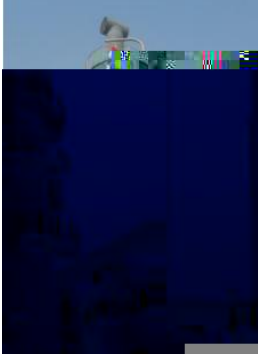

DA006

	
<p>DA007</p>	<p>1#</p>
	
<p>1#</p>	<p>2#</p>
	
<p>3#</p>	<p>DA011</p>
	
<p>DA012</p>	<p>DA013</p>

	
DA014	DA015
	
DA016	DA017
	
DA018	DA019
	
DA020	DA021

	
<p>DA022</p>	<p>DA023</p>
	
<p>1# DA024</p>	<p>2# DA025</p>
	
<p>3# DA026</p>	<p>1</p>
	
<p>1 DA027</p>	<p>2</p>

	
<p>2 DA028</p>	<p>3</p>
	
<p>3 DA029</p>	<p>DA030</p>
	
<p>DA031</p>	<p>DA032</p>

	
<p>DA033</p>	<p>DA034</p>
	
<p>DA035</p>	<p>DA036</p>
	
<p>DA037</p>	<p>DA038</p>
	
	<p>DA039</p>



DA040

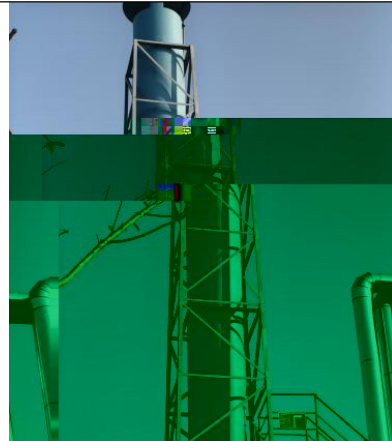

DA054

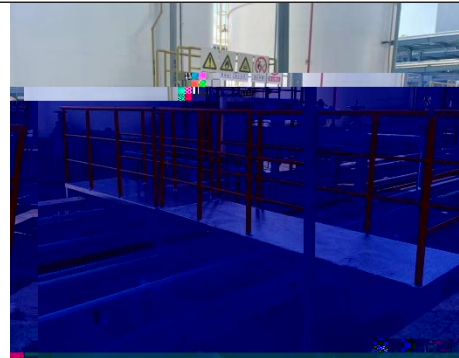

### 4.3

4.3-1

			dB A	/	/	/	/m				
							x	y	z		
1			100	1	2	2	20dB A	135	365	0.5	0.00-24:00
2			100	4	5	5	20dB A	108	389	2	0.00-24:00
3			100	2	2	2	20dB A	126	405	2	0.00-24:00
4			90	2	2	2	20dB A	148	412	0.5	0.00-24:00
5			90	2	2	2	20dB A	142	379	0.5	0.00-24:00
6			90	2	2	2	20dB A	135	368	0.5	0.00-24:00
7			90	1	2	2	20dB A	128	379	0.5	0.00-24:00
8			90	1	2	2	20dB A	136	355	0.5	0.00-24:00
9			90	1	2	2	20dB A	137	364	0.5	0.00-24:00
10			90	1	2	2	20dB A	118	346	0.5	0.00-24:00
11			90	2	2	2	20dB A	127	368	0.5	0.00-24:00
12			90	4	2	2	20dB A	139	353	0.5	0.00-24:00
13			90	2	1	1	20dB A	116	402	0.5	0.00-24:00
14			90	2	2	2	20dB A	109	108	0.5	0.00-24:00
15			90	2	2	2	20dB A	158	389	0.5	0.00-24:00
16			90	2	2	2	20dB A	143	376	0.5	0.00-24:00
17			90	2	2	2	20dB A	133	364	0.5	0.00-24:00
18			90	2	2	2	20dB A	128	386	0.5	0.00-24:00
19			90	2	2	2	20dB A	115	367	0.5	0.00-24:00
20			90	1	1	1	20dB A	122	396	0.5	0.00-24:00
21			90	1	2	2	20dB A	135	386	0.5	0.00-24:00
22			85	1	1	1	20dB A	125	367	5	0.00-24:00
23			85	1	1	1	20dB A	115	399	5	0.00-24:00
24			85	1	1	1	20dB A	116	397	5	0.00-24:00

			dB A	/	/	/		/m			
								x	y	z	
25			85	1	1	1	20dB A	108	410	8	0.00-24:00
26			85	3	1	1	20dB A	215	282	0.5	0.00-24:00
27			100	1	1	1	20dB A	208	305	0.5	0.00-24:00
28			100	1	1	1	20dB A	198	315	0.5	0.00-24:00
29			85	3	3	3	20dB A	305	280	5	0.00-24:00
30			85	3	2	2	20dB A	315	286	5	0.00-24:00
31			85	3	3	3	20dB A	375	294	5	0.00-24:00
32			85	7	9	9	20dB A	620	355	5	0.00-24:00
33			85	1	1	1	20dB A	631	411	5	0.00-24:00
34			100	4	4	4	20dB A	668	408	5	0.00-24:00
35			100	56	16	16	20dB A	633	358	5	0.00-24:00
36			100	2	2	2	20dB A	628	413	8	0.00-24:00
37			100	3	1	1	20dB A	678	375	10	0.00-24:00
38			100	2	2	2	20dB A	627	359	5	0.00-24:00
39			100	6	6	6	20dB A	651	385	6	0.00-24:00
40			100	6	4	4	20dB A	623	362	3	0.00-24:00
41			100	2	2	2	20dB A	638	348	3	0.00-24:00
42			100	1	1	1	20dB A	642	369	15	0.00-24:00
43			100	2	2	2	20dB A	623	356	5	0.00-24:00
44			100	3	2	2	20dB A	628	286	5	0.00-24:00
45			100	2	2	2	20dB A	675	275	5	0.00-24:00
46			100	4	4	4	20dB A	659	301	5	0.00-24:00
47			100	1	2	2	20dB A	658	267	5	0.00-24:00

			dB A	/	/	/		/m			
								x	y	z	
48			100	1	4	4	20dB A	655	275	5	0.00-24:00
49			100	2	2	2	20dB A	200	706	3	0.00-24:00
50			100	1	1	1	20dB A	205	716	5	0.00-24:00

4.3-2

			/	/	/	/dB A	/m				
							x	y	z		
1			2	2	2	85	684	1192	0.5	20dB A	0:00-24:00
2			2	2	2	85	422	1202	0.5	20dB A	0:00-24:00
3			2	2	2	85	702	1183	0.5	20dB A	0:00-24:00
4			1	1	1	85	732	1265	0.5	20dB A	0:00-24:00
5			2	2	2	85	726	1283	0.5	20dB A	0:00-24:00
6			2	2	2	85	692	1168	0.5	20dB A	0:00-24:00
7			1	1	1	85	674	1194	0.5	20dB A	0:00-24:00
8			/	1	1	85	708	1202	0.5	20dB A	0:00-24:00
9			1	1	1	85	688	1243	0.5	20dB A	0:00-24:00
10			1	1	1	85	694	1276	0.5	20dB A	0:00-24:00
11			1	1	1	85	702	1183	0.5	20dB A	0:00-24:00
12			1	1	1	100	723	1242	10	20dB A	0:00-24:00
13			1	1	1	100	673	1192	12	20dB A	0:00-24:00
14			/	4	4	100	734	1272	8	20dB A	0:00-24:00
15			1	1	1	100	708	1226	5	20dB A	0:00-24:00
16			1	1	1	90	711	1186	10	20dB A	0:00-24:00
17			3	3	3	90	251	1208	8	20dB A	0:00-24:00
18			3	3	3	90	267	1302	5	20dB A	0:00-24:00
19			3	3	3	100	282	1183	4	20dB A	0:00-24:00
20			2	2	2	90	276	1182	0.5	20dB A	0:00-24:00
21			2	2	2	90	264	1164	0.5	20dB A	0:00-24:00

			/	/	/	/dB A	/m				
							x	y	z		
22			3	3	3	90	286	1186	0.5	20dB A	0:00-24:00
23			1	1	1	100	385	1167	9	20dB A	0:00-24:00
24			3	3	3	100	405	1178	1	20dB A	0:00-24:00
25			2	2	2	100	416	1192	2	20dB A	0:00-24:00
26			1	1	1	100	435	1162	10	20dB A	0:00-24:00
27			2	2	2	100	392	1175	5	20dB A	0:00-24:00
28			6	6	6	90	356	1201	0.5	20dB A	0:00-24:00
29			3	3	3	90	376	1153	0.5	20dB A	0:00-24:00
30			6	6	6	90	402	1143	0.5	20dB A	0:00-24:00
31			6	6	6	90	320	1135	0.5	20dB A	0:00-24:00
32			6	6	6	90	414	1156	0.5	20dB A	0:00-24:00
33			6	6	6	90	389	1176	0.5	20dB A	0:00-24:00
34			1	1	1	90	365	1180	0.5	20dB A	0:00-24:00
35			3	2	2	90	382	1146	0.5	20dB A	0:00-24:00
36			6	6	6	90	348	1165	0.5	20dB A	0:00-24:00
37			3	3	3	90	425	1158	0.5	20dB A	0:00-24:00
38			3	3	3	90	405	1159	0.5	20dB A	0:00-24:00
39			3	3	3	90	385	1146	0.5	20dB A	0:00-24:00
40			3	2	2	90	397	1132	0.5	20dB A	0:00-24:00
41			2	2	2	90	366	1178	0.5	20dB A	0:00-24:00
42			3	2	2	90	402	1168	0.5	20dB A	0:00-24:00
43			2	1	1	90	408	1149	0.5	20dB A	0:00-24:00

			/	/	/	/dB A	/m				
							x	y	z		
44			1	1	1	90	296	0.76	5	20dB A	0:00-24:00
45		1#	1	1	1	90	305	1082	0.5	20dB A	0:00-24:00
46		2#	1	1	1	90	325	1043	0.5	20dB A	0:00-24:00
47			6	4	4	90	346	1038	0.5	20dB A	0:00-24:00
48			2	2	2	90	312	1056	0.5	20dB A	0:00-24:00
49			2	2	2	90	285	1046	0.5	20dB A	0:00-24:00
50			2	2	2	90	351	1058	0.5	20dB A	0:00-24:00
51			1	1	1	90	348	1083	0.5	20dB A	0:00-24:00
52			2	2	2	85	193	1062	0.5	20dB A	0:00-24:00
53			2	2	2	85	205	1053	0.5	20dB A	0:00-24:00
54			1	1	1	85	216	1046	0.5	20dB A	0:00-24:00
55			2	2	2	85	222	1038	5	20dB A	0:00-24:00
56			3	2	2	85	234	1028	5	20dB A	0:00-24:00
57			2	2	2	85	242	1018	8	20dB A	0:00-24:00
58			2	1	1	85	180	1046	8	20dB A	0:00-24:00
59			1	1	1	100	168	956	10	20dB A	0:00-24:00
60			2	2	2	85	208	987	0.5	20dB A	0:00-24:00
61			1	2	2	90	632	351	0.5	20dB A	0:00-24:00
62		II	8	2	2	90	641	382	0.5	20dB A	0:00-24:00
63		I	3	3	3	90	643	375	0.5	20dB A	0:00-24:00
64			4	8	8	90	615	368	0.5	20dB A	0:00-24:00
65			4	8	8	90	628	348	0.5	20dB A	0:00-24:00

			/	/	/	/dB A	/m					
							x	y	z			
66		I	2	2	2	90	635	345	0.5	20dB	A	0:00-24:00
67			2	6	6	90	608	385	0.5	20dB	A	0:00-24:00
68			1	1	1	90	382	302	0.5	20dB	A	0:00-24:00
69		II	3	3	3	90	426	312	0.5	20dB	A	0:00-24:00
70		II	2	1	1	90	432	300	0.5	20dB	A	0:00-24:00
71			2	2	2	90	392	303	0.5	20dB	A	0:00-24:00
72			2	2	2	90	445	299	0.5	20dB	A	0:00-24:00
73			2	2	2	90	427	313	0.5	20dB	A	0:00-24:00
74			2	2	2	90	396	301	0.5	20dB	A	0:00-24:00
75			2	2	2	90	456	271	0.5	20dB	A	0:00-24:00
76			2	2	2	90	423	298	0.5	20dB	A	0:00-24:00
77			2	3	3	90	397	314	0.5	20dB	A	0:00-24:00
78			4	5	5	90	467	276	0.5	20dB	A	0:00-24:00
79			2	2	2	90	429	295	0.5	20dB	A	0:00-24:00
80			1	2	2	90	398	304	0.5	20dB	A	0:00-24:00
81		I	3	3	3	90	468	275	0.5	20dB	A	0:00-24:00
82		II	3	3	3	90	421	315	0.5	20dB	A	0:00-24:00
83			1	2	2	90	399	273	0.5	20dB	A	0:00-24:00
84			9	3	3	90	478	294	0.5	20dB	A	0:00-24:00
85			2	2	2	90	420	308	0.5	20dB	A	0:00-24:00
86			9	9	9	90	490	293	0.5	20dB	A	0:00-24:00
87			12	12	12	90	275	342	0.5	20dB	A	0:00-24:00

			/	/	/	/dB A	/m				
							x	y	z		
88			3	3	3	90	335	346	0.5	20dB A	0:00-24:00
89			6	6	6	90	282	343	0.5	20dB A	0:00-24:00
90			1	2	2	90	294	364	0.5	20dB A	0:00-24:00
91			6	6	6	90	268	372	0.5	20dB A	0:00-24:00
92			2	8	8	90	269	346	0.5	20dB A	0:00-24:00
93			3	3	3	90	333	371	0.5	20dB A	0:00-24:00
94			3	3	3	90	310	353	0.5	20dB A	0:00-24:00
95			6	4	4	90	305	348	0.5	20dB A	0:00-24:00
96			6	4	4	90	325	351	0.5	20dB A	0:00-24:00
97			2	2	2	90	269	381	0.5	20dB A	0:00-24:00
98			2	2	2	90	308	341	0.5	20dB A	0:00-24:00
99			2	2	2	90	315	380	0.5	20dB A	0:00-24:00
100			2	2	2	90	336	366	0.5	20dB A	0:00-24:00
101			2	2	2	90	306	340	0.5	20dB A	0:00-24:00
102			3	2	2	90	325	335	0.5	20dB A	0:00-24:00
103			2	1	1	90	307	368	0.5	20dB A	0:00-24:00
104			2	2	2	90	318	363	0.5	20dB A	0:00-24:00
105			2	2	2	90	308	336	0.5	20dB A	0:00-24:00
106			2	2	2	90	316	365	0.5	20dB A	0:00-24:00
107			4	6	6	85	309	382	5	20dB A	0:00-24:00
108			1	2	2	85	337	337	5	20dB A	0:00-24:00
109			40	40	40	85	245	962	0.5	20dB A	0:00-24:00

			/	/	/	/dB A	/m				
							x	y	z		
110			56	56	56	85	375	239	0.5	20dB A	0:00-24:00
111		/ /	10	10	10	85	137	1004	0.5	20dB A	0:00-24:00
112			1	1	1	90	42	1107	1.5	20dB A	0:00-24:00
113			1	1	1	90	42	1132	1.5	20dB A	0:00-24:00
114			1	1	1	90	37	1165	1.5	20dB A	0:00-24:00
115			1	1	1	90	156	1147	1.5	20dB A	0:00-24:00
116			1	1	1	90	182	1147	1.5	20dB A	0:00-24:00
117			1	1	1	90	207	1147	1.5	20dB A	0:00-24:00
118			1	1	1	90	154	1147	1.5	20dB A	0:00-24:00
119			1	1	1	90	180	1147	1.5	20dB A	0:00-24:00
120			/	1	1	90	205	1147	1.5	20dB A	0:00-24:00
121			/	1	1	90	207	1147	1.5	20dB A	0:00-24:00
122			/	1	1	90	207	1146	1.5	20dB A	0:00-24:00
123			/	1	1	90	207	1146	1.5	20dB A	0:00-24:00
124			/	1	1	90	205	1230	1.5	20dB A	0:00-24:00
125			/	1	1	90	238	937	1.5	20dB A	0:00-24:00
126			/	1	1	90	65	252	1.5	20dB A	0:00-24:00
127			/	13	13	90	528	675	1.5	20dB A	0:00-24:00

### 4.3.1

1

2

3

4

### 4.3.2

1

2

- " "

5dB

A

3

5

6



## 4.4

4.4-1

4.4-1

					t/a	t/a	t	t	t	
		S1101_			22.5	22.5	/	/	/	/
		S2101_			117908	117908	44691.28	44691.28	1500	
		S2201_			47797	47797	5150.42	5150.42	/	
	AB	S3101_	HW50 261-167-50		7.73	7.73	/	/	/	/
		S3102_	HW50 261-167-50		21.67	21.67	/	/	/	/
		S3103_	HW50 261-167-50		21.67	21.67	/	/	/	/
		S4101_			6.7	6.7	/	/	/	/
		S5101_	HW50 261-167-50		8	8	/	/	/	/
		S5102_	HW50 261-167-50		3	3	/	/	/	/
		S5103_	HW50 261-167-50		6	6	/	/	/	/
		S5104_	HW50 261-167-50		2	2	/	/	/	/
		S6101_	HW50 261-167-50		9.9	9.9	/	/	/	/
		S7101_			4544	4544	3881.54	3881.54	/	

					t/a	t/a	t	t	t	
			HW08 900-214-08		10	10	6.658	/	6.658	/
	UPS		HW31 900-052-31		5.65	5.65	/	/	/	/
			HW49 900-041-49		1	1	/	/	/	/
			HW49 900-047-49		0.2	0.2	0.19	/	0.9	/
			HW49 900-041-49		3	3	0.02	/	0.02	/
						3330				
			/		2887	500	1849.84	1849.84	/	
						5328				
			/		30	30	/	/	/	/
			/		/	560	/	/	/	/
	SCR		HW50 772-007-50		3.76	3.76	/	/	/	/
			HW49 900-039-49		15.3025	15.3025	/	/	/	/
			/	HW49 900-041-49	/	2	/	/	/	/
			HW08		3.52	3.52	/	/	/	/

					<b>t/a</b>	<b>t/a</b>	<b>t</b>	<b>t</b>	<b>t</b>	
			900-249-08							
					1.2	1.2	/	/	/	/
					11	11	/	/	/	/

12

704.12m<sup>2</sup>

2468.56m<sup>2</sup>

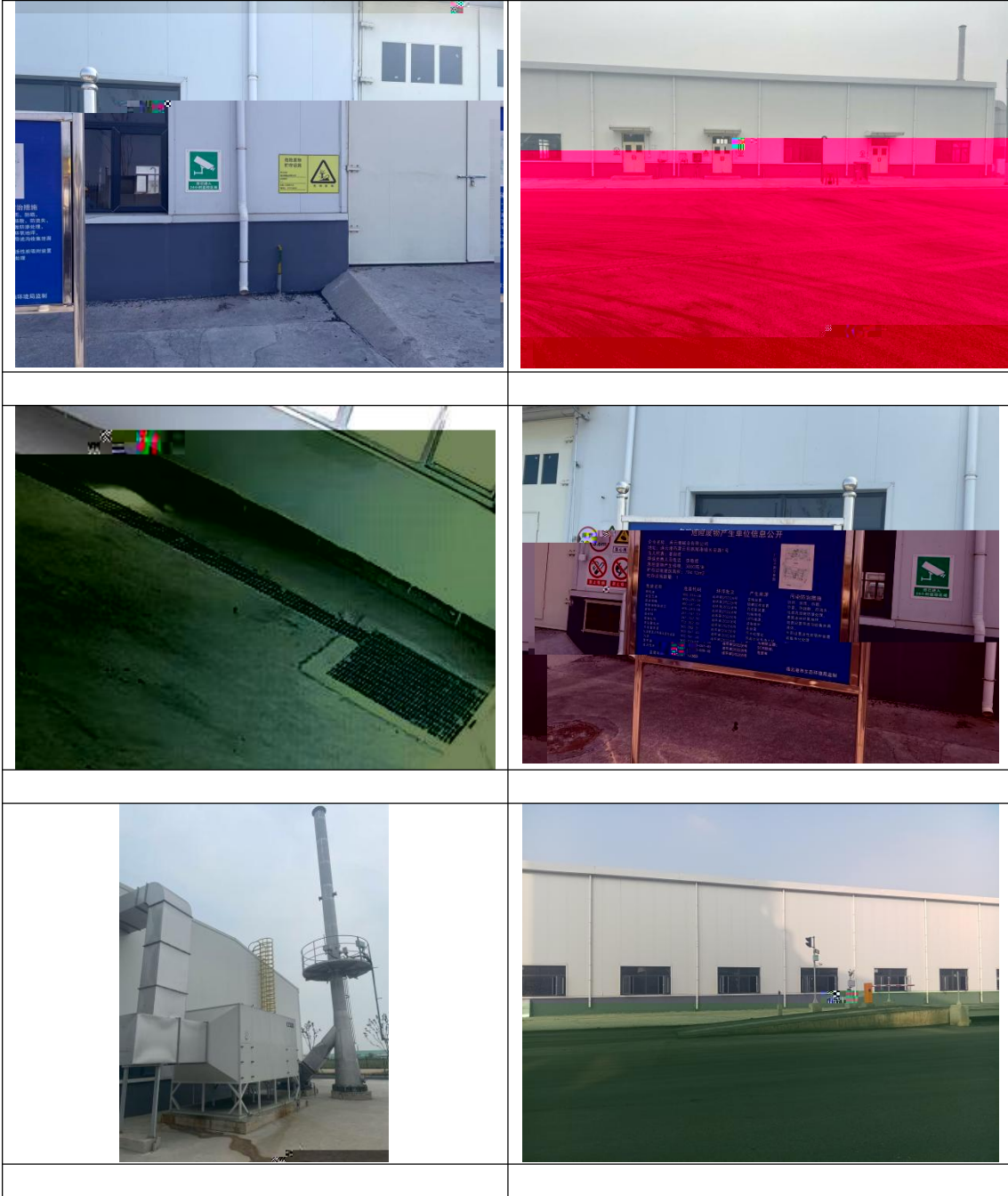

## 4.5

### 4.5.1

#### 4.5.1.1

4.5.1-1

		m <sup>3</sup>		m <sup>3</sup>
		3500	3	12155
		500	2	906

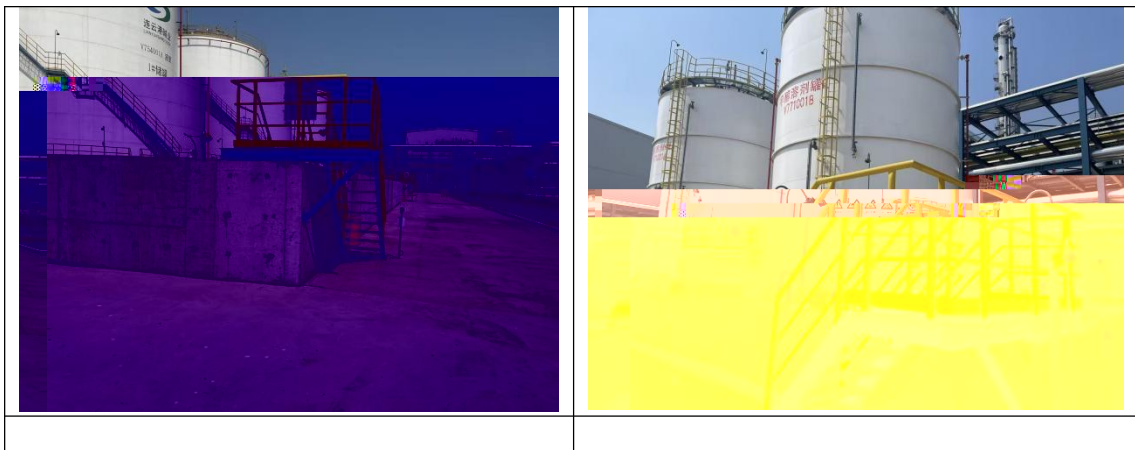

#### 4.5.1.2

2mm + P6  
 150mm  
 P8 250mm +  
 1mm  
 100mm P6

4.5.1-2

--	--	--	--	--	--



**4.5.1.3**

1	2	13376m <sup>3</sup>
7400m <sup>3</sup>		
2	10	1353.5m <sup>3</sup>
3	2	3080m <sup>3</sup>
3830m <sup>3</sup>		

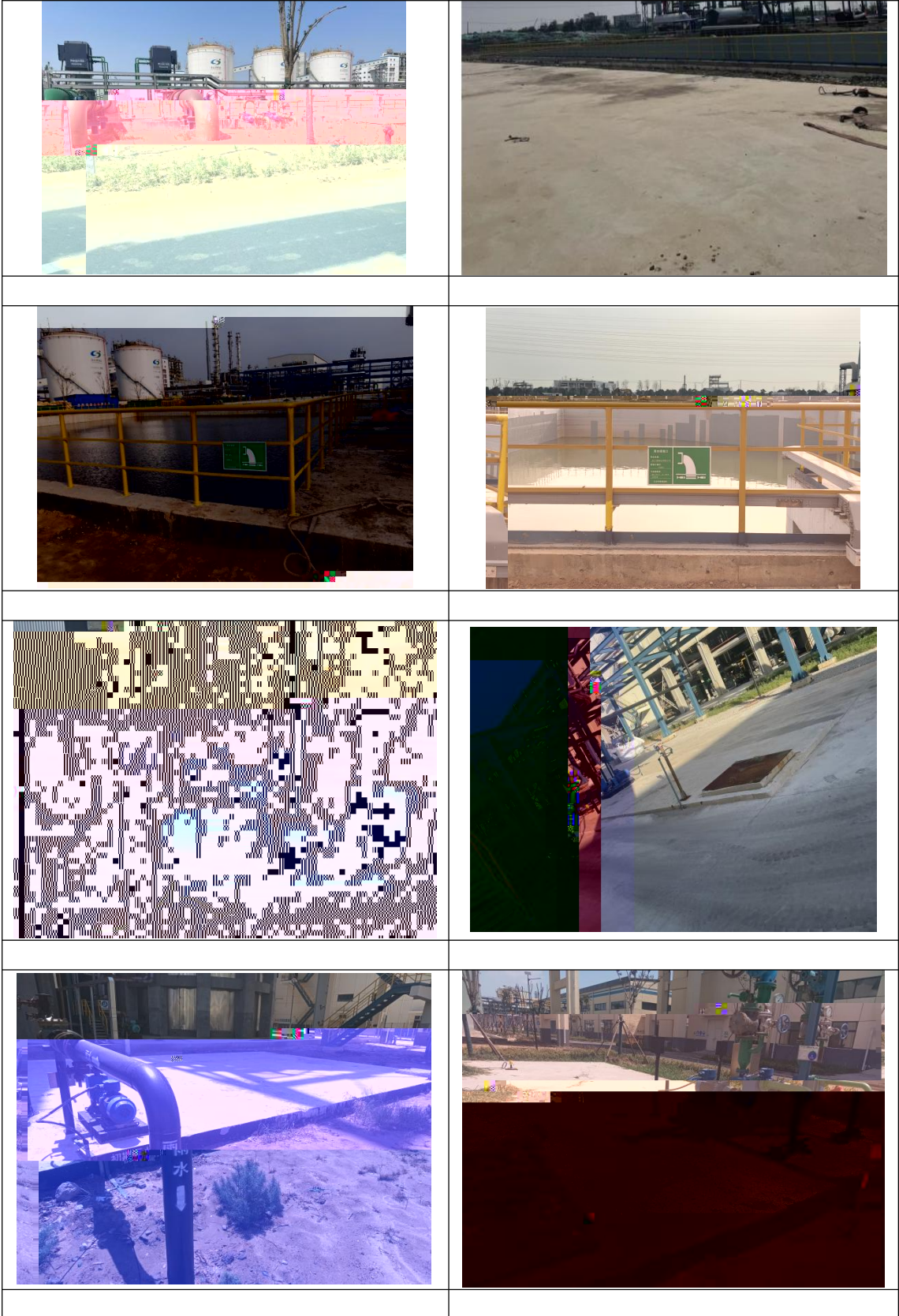

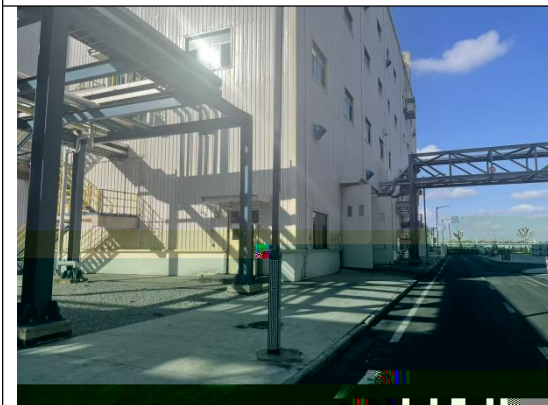
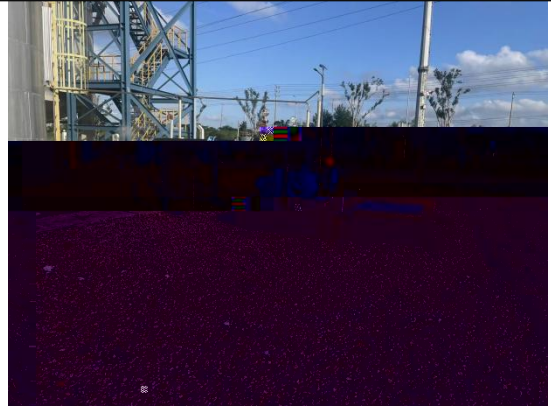

#### 4.5.1.4

1

4.5.1-3

4.5.1-4

#### 4.5.1-3

1		10			1391215654
2		16			
3		10			
4		2			
5		2			
6		2			
7		1			
8		2			
9		2			
10		10			
11		6			
12		10			
13		20			
14		20			
15		10			
16		5			
17		10			
18		5			
19		10			
20		2			
21		20			
22	25m	10			
23		10			
24	ABC 4KG	20			
25		5			
26		5			
27		4			
28		2			
29		1			
30		5			
31		2			
32		1			
33					
34		2			

35		20			
36	25m	10			
37		4			
38		4			
39	50	2			
40	50	2			
41		5			
42		10			
43		10			
44		10			
45		2			
46		5			
47		14			
48	AED	1			
49		1			
50		1	100 kg		
51		10			
52		2	1300 N		
53		1	2500 N 30 m		
54		1			
55		2	50 m		
56		1	GB/T 17906		



				13912156546	
				13812326799	
				13815660296	
				18805138844	
				13812348870	
				13861421601	
				13775590876	
				13961391775	
4				13812325037	
				15150939956	
				15996111388	
				15351850886	
				13611559685	
				18151256068	
				18912166800	
				18061347890	
				13812335525	
				13815663609	
				18005138889	
				19851133316	
				138-1232-0222	
				15705155182	
				15151261067	
				18360691995	
				13805137022	
				13851262413	
				13851296385	
				15705151370	
				15247887255	
				13815663530	
				13815656508	
				18761398023	
				15705153271	
				13775598954	
				13775497258	
				17751856555	
				18205135069	
				137-7548-2111	
				13961397781	
				15061332223	
				18751244797	

### 4.5.1.5

1

2

3

4

5

6

35%

7

8

9

2025 6

24

320723-2025-044-H

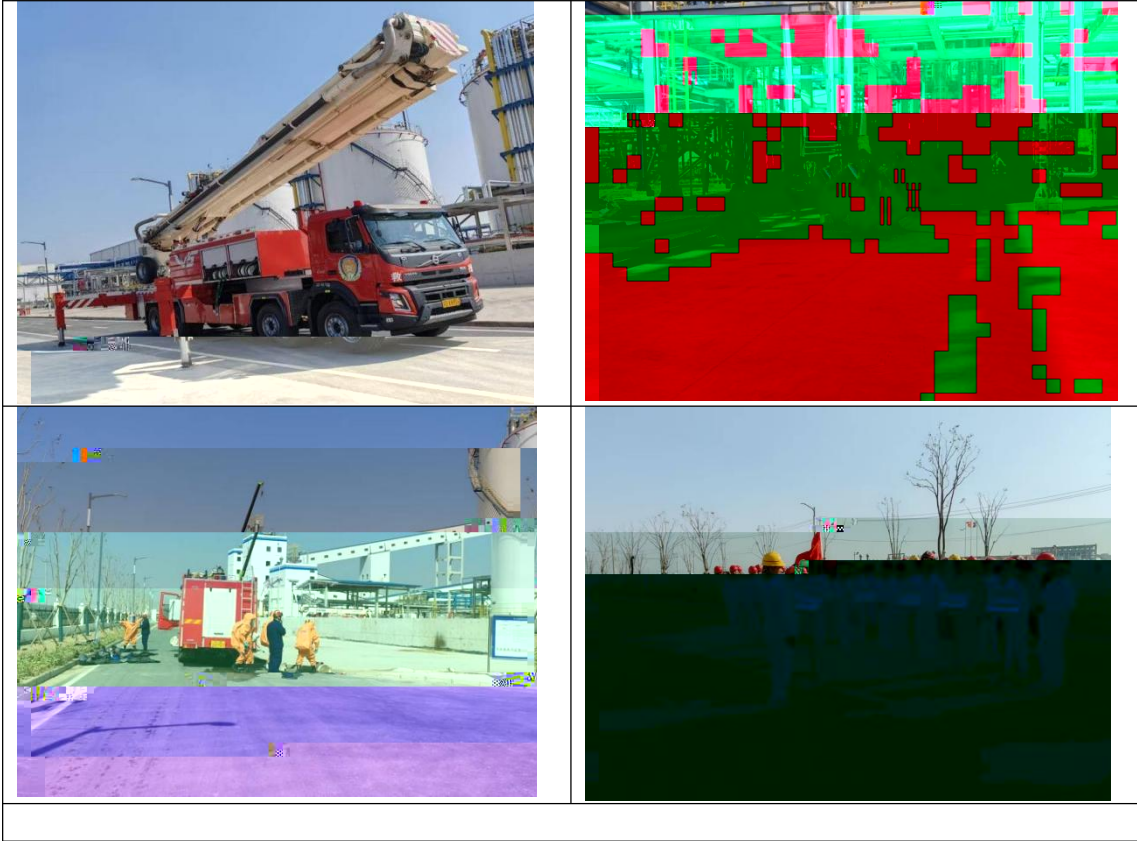

4.6

GB15562.1-2-

1995

2

1

2025 2 11

91320700MA1MFBW470003V

COD pH

pH COD

DA006

SO<sub>2</sub>

DA039

VOCs

DA054

VOCs



4.7

14.9%      37581.7m<sup>2</sup>      11.47%      230770m<sup>2</sup>

## 4.8

“ ”

### 4.8.1

447300

8572.988

1.9%

“ ”

4.8.1-1

#### 4.8.1-1

		800	39.77
		1200	481.328
		50	30
		50	35
		50	40
		1000	1282
	+	200	180
	SCR	100	80
	+	100	83
	AO	1000	1608
		100	60
		400	2566
		500	90.69
		500	200
		800	300
		/	/
		500	180
		1200	527.2
		50	30
		20	760
		9420	8572.988

### 4.8.2

4.8.2-1

4.8.2-1

“ ”

		+		
		+	+    +	+    +
		+	+	+
			1	1
		+    +	+    +	+    +
			+	+
			+	+
	1~3#	3	3	3

	1#~3#	3	3	3	
	1~3	3	3	3	
		+	+	+	
		SCR	SCR	SCR	
		1	13 +	13 +	
AO					
		GB/T19923-2005 GB/T 50050-2017	GB/T19923-2024 50050-2017 GB/T		

711.99m<sup>2</sup>  
711.99m<sup>2</sup>

704.12m<sup>2</sup>

704.12m<sup>2</sup>

1 2484.18m<sup>2</sup>

1 24687.56m<sup>2</sup>

1 24687.56m<sup>2</sup>

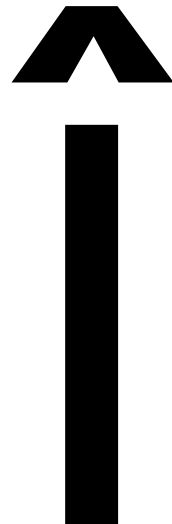

# 5

## 5.1

## 5.2

2022 5 28

2022 6

99  
228 582805.24 9420  
120 / 110 /  
110 / :80 / 30  
/ 110 / 40 1  
4.5 Nm3/ 100 /  
110KV  
6.5 / 5.4 1  
2.2 1.2 1 4.8 1 4800 /  
1.6 /

“ ”

“

”

GB/T19923-2005

GB/T50050-2017

GB18918-2002 A

DB32/939-2020

2 3 4

GB18918-2002 A

DB32/939-2020 2 3 4

+

+

+

+

1#-3#

1#-3#

1#-3#

10

+

SCR

40

H1-H40

GB31570-2015 4

GB31573-2015 4

DB32/4041-2021 1

DB32/4041-2021 1 3

SO SO NOx  
GB31570-2015 4

DB32/4041-2021 1 3 NOx  
DB32/4041-2021 1 3

GB31571-2015 6

DB32/3151-2016

1 2

DB32/3151-2016 1

2

NMHC

DB32/4041-2021

2

GB14554-93

1 2

DB32/4041-2021 3

200m

GB12348-2008 3

G228

GB12348-2008 4

GB12523-2011

“

”

GB18599-2020

GB18597-2001

2019 327

“

”

GB/T50934-2013

44.6104t/a NO<sub>x</sub> 7.1152t/a  
 SO<sub>2</sub> 2.6596t/a H<sub>2</sub>S 0.1702t/a 52.5006t/a 1.7983t/a VOCs 2.3659t/a  
 : 42.9493t/a HS 0.0209t/a 7.8067t/a  
 HCl 0.0003t/a 1.6975 t/a VOCs 1.9958t/a.  
 ( ) 1960256t/a COD 424.732t/a  
 SS 247.5101t/a NH<sub>3</sub>-N 23.5142t/a 41.1499t/a 0.122t/a  
 17.0512t/a 0.32t/a 8.6286t/a 0.16t/a 0.0058t/a  
 8776.24t/a  
 : 1960256t/a COD 92.9728t/a  
 SS 19.6026t/a NH<sub>3</sub>-N 11.1037t/a 25.6238t/a 0.122t/a  
 5.1248t/a 0.32t/a 8.6286t/a 0.16t/a 0.0058t/a  
 8776.24t/a

2014 66

2017 78

HJ880-2017

“ ”

5.3 “ ”

5.3-1 “ ”

1

È

1

7-

F9€Dm&

Lu

η ο π λ γ λ  
)

Εδδ ΕΙ ΟΧ Λμ ΧΟ

Ε.ρ  
Πόνος

Δ

ΕΣΗΛΗ  
Θ

Χ

2

Β

Π

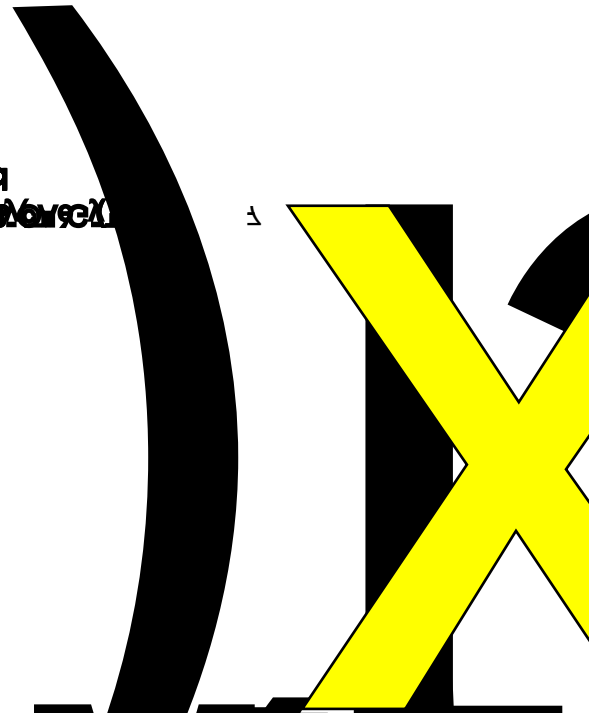





	<p style="text-align: center;">”</p> <p style="text-align: center;">GB18599-2020</p> <p style="text-align: center;">GB18597-2001</p> <p style="text-align: right;">2019 327</p>	<p style="text-align: center;">“ ”</p> <p style="text-align: center;">GB18597-2001</p> <p style="text-align: center;">GB18597-2023</p>
6	<p style="text-align: center;">”</p> <p style="text-align: center;">GB/T50934-2013</p>	<p style="text-align: center;">“ ”</p>
7	<p style="text-align: center;">7</p> <p style="text-align: center;">2020 101</p>	<p style="text-align: center;">2</p> <p style="text-align: center;">13376m<sup>3</sup></p> <p style="text-align: center;">7400m<sup>3</sup></p> <p style="text-align: center;">2020 101</p>
8	<p style="text-align: center;">8</p> <p style="text-align: center;">2014 66</p>	

9

HJ880-20170

9

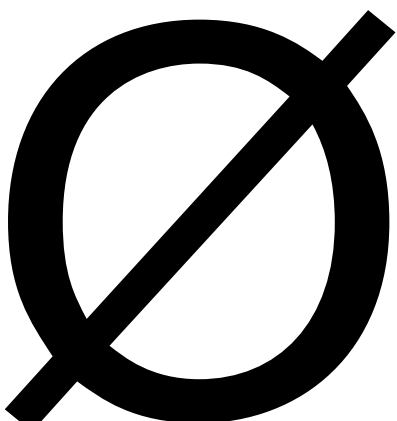

155

155

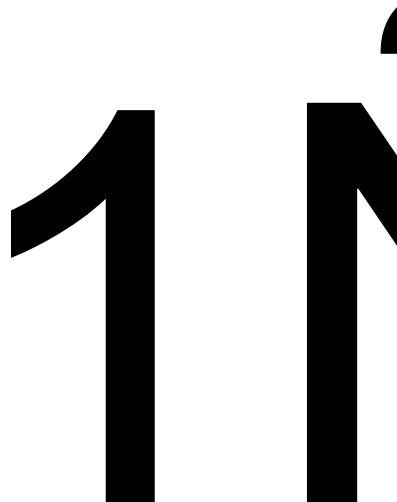

# 6

## 6.1

6.1-1

GB 31573-2015

31573-2015

31573-2015

GB

GB

DB32/4041-2021

GB14554-93

DA003~DA005 DA008~DA0010 DA012 DA017~DA034 DA038

DB32/4041-2021 DA001

DB32/ 4385-2022

DB32/ 4385-2022

1

3.5%

GB31570-2015

2024

6.1-1

		mg/m <sup>3</sup>	kg/h		
		20	1	B32/4041-2021 1	D DA003~DA005
	SO <sub>2</sub>	100	1.4	70-2015 4 2/4041-2021 1	GB315 DB3 DA006
		/	75 64m	GB14554-93 2	
		/	5.2 64m		
		/	9.3 80m		
		50	54 80m	71-2015 6 2016 1	GB315 DB32/3151- DA002
	NMHC	60	3	B32/4041-2021 1	D
	SO <sub>2</sub>	100	1.4	70-2015 4 2/4041-2021 1	GB315 DB3 DA006
	NO <sub>x</sub>	100	0.47	70-2015 4 2/4041-2021 1	GB315 DB3
		/	5.2 64m	GB14554-93 1 2	
		10	1	GB31573-2015 4	DB3 DA007

		mg/m <sup>3</sup>	kg/h		
				2/4041-2021	1
		/	8.7 20m	GB14554-93	2
		/	20 32m		
		/	35 40m		
		/	35 45m		
		/	0.33 15m	DB32/4041-2021	1
		/	4.9 15m		
		60	3		
		/	4.9 17m	GB14554-93	2
		50	1.8	DB32/4041-2021	1
		60	3		
		60	3		
		20	1	B32/4041-2021	1
		60	3.6		D
				DB32/3151-2016	
				1	
		2.28	/	DB32/ 4385-2022	DA001
		10	/		
		50	/		

VOCs

NMHC

DB32/4041-2021

2

6.1-2

6.1-2		NMHC	mg/m <sup>3</sup>
	6	1h	
	20		

DB32/4041-2021

3

DB32/3151-2016

2

1

6.1-3

6.1-3		mg/m <sup>3</sup>
	0.5	DB32/4041-2021
	0.05	
	4.0	
	1	DB32/3151-2016
	1.5	GB14554-93
	0.06	

## 6.2

GB 13458-2013

6.2-1

GB18918-2002

A

DB32/939-2020

2

3

4

6.2-1

1	pH		6~9	6~9
2	COD <sub>Cr</sub>	mg/L	200	50

3	NH <sub>3</sub> -N	mg/L	50	5 8 *
4		mg/L	3	1
5	SS	mg/L	100	10
6		mg/L	0.2	0.2
7		mg/L	0.5	0.5
8		mg/L	1.5	0.5
9	TN	mg/L	60	15
10		mg/L	0.1	0.5
11		mg/L	5000	/

>12

12

DB32/939-2020 1

3 4

GB/T19923-2024

GB/T

50050-2017

**6.2-2**

**mg/L**

1	pH	6.5~9.0
2	NTU	5
3		20
4	BOD <sub>5</sub>	10
5	COD <sub>cr</sub>	50
6		—
7		1
8		250
9		5 1
10	CaCO <sub>3</sub>	450
11	CaCO <sub>3</sub>	350
12		0.5
13		250

**6.3**

GB12348-2008 3

G228

GB12348-2008 4

6.3-1

**6.3-1**

**dB A**

	65	55	GB12348-2008 3
	70	55	GB12348-2008 4

**6.4**

GB18599-2

020

GB18597-2023

**6.5**

44.6104t/a NOx 7.1152t/a  
 SO<sub>2</sub> 2.6596t/a H<sub>2</sub>S 0.1702t/a 52.5006t/a 1.7983t/a VOCs 2.3659t/a  
 : 42.9493t/a HS 0.0209t/a 7.8067t/a  
 HCl 0.0003t/a 1.6975 t/a VOCs 1.9958t/a.  
 1960256t/a COD 424.732t/a  
 SS 247.5101t/a NH<sub>3</sub>-N 23.5142t/a 41.1499t/a 0.122t/a  
 17.0512t/a 0.32t/a 8.6286t/a 0.16t/a 0.0058t/a  
 8776.24t/a  
 : 1960256t/a COD 92.9728t/a  
 SS 19.6026t/a NH<sub>3</sub>-N 11.1037t/a 25.6238t/a 0.122t/a  
 5.1248t/a 0.32t/a 8.6286t/a 0.16t/a 0.0058t/a  
 8776.24t/a

# 7

## 7.1

2025 8 12 28 11 3 ~4

2

## 7.2

7.2-1

7.2-1

	W1		pH	COD	SS	TDS	2 4
	W2						
	W3		pH	COD	SS		
	W4		TDS				



## 7.3







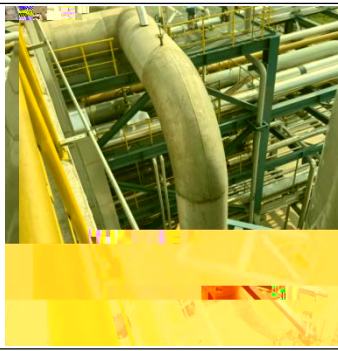
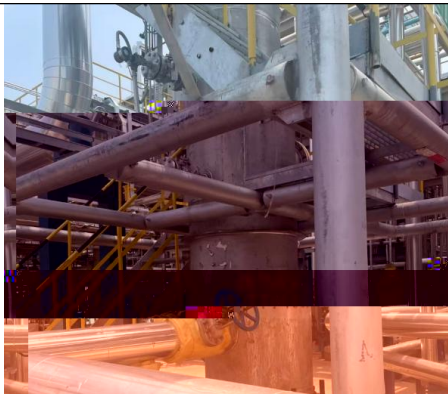

### 7.3.1

7.3.1/

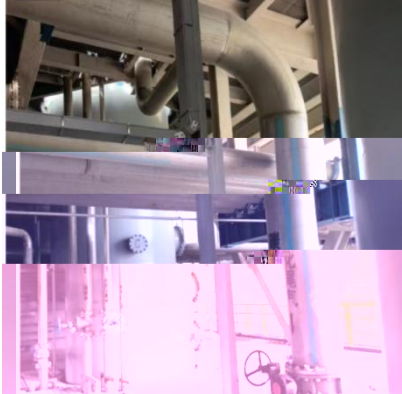
	1#		
DA009	2#		
	2#		
DA010	3#		
	3#		
DA011		NH <sub>3</sub>	
DA012			
DA013		NH <sub>3</sub>	
DA014		NH <sub>3</sub>	
DA015	2	NH <sub>3</sub>	
DA016		NH <sub>3</sub>	
DA017			
DA018			
DA019			
DA020			
DA021			
DA022			
DA023			
DA024	1#		
DA025	2#		
DA026	3#		
DA027	1		
	1		
DA028	2		
	2		
DA029	3		
	3		
DA030			
DA031			
DA032			
DA033			
DA034			
DA035		NH <sub>3</sub>	
DA036		NH <sub>3</sub>	
DA037		NH <sub>3</sub>	

DA038			
DA039		NMHC	
DA040		NMHC	
DA041		NH <sub>3</sub>	NMHC
DA043		NH <sub>3</sub>	NMHC
DA044		NH <sub>3</sub>	NMHC
DA047		NH <sub>3</sub>	NMHC
DA050		NH <sub>3</sub>	NMHC
DA052		NH <sub>3</sub>	NMHC
DA053		NH <sub>3</sub>	NMHC
DA054	2	NH <sub>3</sub>	H <sub>2</sub> S NMHC
DA054		NH <sub>3</sub>	H <sub>2</sub> S NMHC

	
DA001	DA002
	
DA006	DA007

	
<p>DA011</p>	<p>DA012</p>
	
<p>DA013</p>	<p>DA014</p>
	
<p>DA016</p>	<p>DA020</p>
	
<p>DA021</p>	<p>DA024</p>



DA



# 8

## 8.1

8.1-1

### 8.1-1

	HJ 836-2017		AUM120D	MST-01-06
	HJ 693-2014		YQ3000-D	MST-09-39
	HJ 57-2017		YQ3000-D	MST-09-39
	HJ 1388-2024		UV-1800	MST-03-08
	HJ/T 398-2007		HM-LG30	MST-15-47
	HJ/T 33-1999		GC9890B	MST-04-03
	HJ 38-2017		GC9560	MST-04-04
	HJ 533-2009		UV-1800	MST-03-08
	HJ 1263-2022		FA1265SE M	MST-01-12
	HJ/T 33-1999		GC9890B	MST-04-03
	HJ 533-2009		UV-1800	MST-03-08
	HJ 549-2016		ICS600	MST-04-06
	-	HJ	GC112N	MST-04-14 MST-04-15
	604-2017			
		2003		
	3.1.11.2			
pH	pH		PH100A	MST-15-41
	HJ 1147-2020		PHBJ-260	MST-15-38
	HJ 828-2017		50mL	
	GB/T 11901-1989		FA2204B	MST-01-07

HJ 535-2009

UV-1800 MST-03-02

8.2-1

		HJ 836-2017		AUM120D	MST-01-06	2025.05.08~2026.05.07
	16157-1996	GB/T 2017 87		FA2204B	MST-01-07	2025.05.08~2026.05.07
	693-2014	HJ		YQ3000-D	MST-09-39	2024.10.17~2025.10.16
	57-2017	HJ		YQ3000-D	MST-09-39	2024.10.17~2025.10.16
	1388-2024	HJ		UV-1800	MST-03-08	2025.05.08~2026.05.07
	HJ/T 398-2007			HM-LG30	MST-15-47	2025.02.26~2026.02.25
		HJ/T 33-1999		GC9890B	MST-04-03	2025.05.08~2026.05.07
	HJ 38-2017			GC9560	MST-04-04	2025.05.08~2026.05.07
	533-2009	HJ		UV-1800	MST-03-08	2025.05.08~2026.05.07
		HJ 1263-2022		FA1265SEM	MST-01-12	2024.10.10~2025.10.09
		HJ/T 33-1999		GC9890B	MST-04-03	2025.05.08~2026.05.07
	533-2009	HJ		UV-1800	MST-03-08	2025.05.08~2026.05.07
		HJ 549-2016		ICS600	MST-04-06	2025.05.08~2026.05.07
		-		GC112N	MST-04-15	2025.07.28~2026.07.27
	HJ 604-2017			GC112N	MST-04-14	2025.05.08~2026.05.07
	pH	pH HJ 1147-2020	PH	PH100A	MST-15-41	2025.05.08~2026.05.07
			PH	PHBJ-260	MST-15-38	2025.05.08~2026.05.07
		HJ 828-2017		50mL		

GB/T 11901-1989

FA2204B MST-01-07 2025.05.08~2026.05.07

HJ 535-2009

UV-1800 MST-03-02 2025.05.08~2026.05.07

• w b 8

8.3

8.4

w\$

8.5

				%		%		%		%		%		%
		90	/	/	10	100	/	/	4	100	2	100	2	100
pH		240	26	100	/	/	/	/	/	/	/	/	/	/
		240	26	100	10	100	/	/	4	100	2	100	8	100
		240	26	100	/	/	/	/	/	/	/	/	/	/
		192	22	100	4	100	2	100	/	/	2	100	4	100
		192	22	100	4	100	2	100	/	/	2	100	4	100
		192	22	100	4	100	2	100	/	/	2	100	4	100
		192	22	100	4	100	2	100	/	/	2	100	4	100
		192	22	100	4	100	2	100	/	/	2	100	4	100
		192	22	100	2	100	2	100	/	/	2	100	4	100
		192	22	100	4	100	2	100	2	100	2	100	2	100
		192	22	100	/	/	/	/	1	100	2	100	1	100
	103 105		240	26	100	/	/	/	/	/	/	/	/	/

## 8.6

HJ/T 373-2007

GB/T

16157-1996

## 8.7

0.5dB



# 9

## 9.1

2025 8 12 -27 11 3 -4

### 9.1-1

	8.12	1680	630	2328	7.5	140	113	49.7	27.4	1191	34.5
	8.13	1683	622	2342	7	138	118	51.7	29.4	1177	36.5
	8.14	1690	649	2379	8.2	130	121	48.7	26.4	1180	33.5
	8.15	1630	687	2343	7.1	136	117	48.6	26.3	1180	33.4
	8.16	1680	665	2363	6.9	130	126	49.8	27.5	1175	34.6
	8.17	1702	613	2389	6.9	128	125	50.7	28.4	1186	35.5
	8.18	1689	625	2356	8.1	153	109	54.2	31.9	1190	39
	8.19	1698	738	2488	8.1	146	119	50.2	27.9	1179	35
	8.20	1600	734	2357	7.2	144	124	48.7	26.4	1183	33.5
	8.21	1730	599	2385	7.4	140	110	49.2	26.9	1175	34
	8.22	1706	658	2396	7.15	136	126	51.2	28.9	1170	35.7
	8.23	1800	525	2376	7.1	120	125	48.5	26.2	1183	33.3
	8.24	1699	613	2365	7.25	134	127	48.9	26.6	1184	33.7
	8.25	1786	522	2357	7.6	132	118	50.7	28.4	1182	35.5
	8.26	1823	394	2287	7.55	152	116	50.2	27.9	1193	35
	8.27	1700	622	2389	7.7	135	120	52.2	29.9	1186	37

11.3	1685	644	2358	7.2	135	125	51.2	28.9	1201	35.5
11.4	1720	581	2359	7.45	136	125	50.2	27.9	1204	35.2
t/a	800000	245920	1100000	4714	62000					

100 1000 12 100 ( 100 100 82 2 5

			kg/h	0.031	0.032	0.035	0.034	0.037	0.031	/	0.033	/	/
DA004		/	Nm <sup>3</sup> /h	4263	4023	4375	4116	3869	4192	/	4139.667	/	/
			mg/m <sup>3</sup>	2	1.6	2.2	1.5	2.7	1.9	/	1.983	20	
			kg/h	8.53×10 <sup>-3</sup>	6.44×10 <sup>-3</sup>	9.63×10 <sup>-3</sup>	6.17×10 <sup>-3</sup>	0.01	7.96×10 <sup>-3</sup>	75.64%	0.008	1	
DA005		/	Nm <sup>3</sup> /h	1945	1971	1898	1880	1906	1926	/	1921	/	/
			mg/m <sup>3</sup>	25.5	29.8	27.9	28	26.4	28.6	/	27.7	/	/
			kg/h	0.05	0.059	0.053	0.053	0.05	0.055	/	0.053	/	/
DA005		/	Nm <sup>3</sup> /h	2155	2156	2206	2239	2140	2244	/	2190	/	/
			mg/m <sup>3</sup>	1.6	2	2.3	1.8	1.6	2.1	/	1.9	20	
			kg/h	3.45×10 <sup>-3</sup>	4.31×10 <sup>-3</sup>	5.07×10 <sup>-3</sup>	4.03×10 <sup>-3</sup>	3.42×10 <sup>-3</sup>	4.71×10 <sup>-3</sup>	92.19%	0.004	1	
DA008 1#		/	Nm <sup>3</sup> /h	13634	13317	13469	13583	13539	13517	/	13509.833	/	/
			mg/m <sup>3</sup>	25.9	27.8	28.2	26.7	25.6	27.6	/	26.967	/	/
			kg/h	0.353	0.37	0.38	0.363	0.347	0.373	/	0.364	/	/
DA008 1#		/	Nm <sup>3</sup> /h	13208	13870	12974	13281	13584	13292	/	13368.167	/	/
			mg/m <sup>3</sup>	2.4	2	1.7	1.4	1.9	2.2	/	1.933	20	
			kg/h	0.032	0.028	0.022	0.019	0.026	0.029	92.86%	0.026	1	
DA023		/	Nm <sup>3</sup> /h	13228	13309	13307	13411	13348	13168	/	13295.167	/	/
			mg/m <sup>3</sup>	9.1	9.5	8.4	8.7	9.8	7.8	/	8.883	/	/
			kg/h	0.12	0.126	0.112	0.117	0.131	0.103	/	0.118	/	/
DA023		/	Nm <sup>3</sup> /h	11946	11337	11421	12027	12385	12476	/	11932	/	/
			mg/m <sup>3</sup>	2.8	2.4	1.9	1.7	2.1	2.5	/	2.233	20	
			kg/h	0.033	0.027	0.022	0.02	0.026	0.031	77.57%	0.027	1	
DA027		/	Nm <sup>3</sup> /h	3973	4114	4036	4086	4016	4156	/	4063.5	/	/
			mg/m <sup>3</sup>	8.3	9.4	8.9	8.1	8.6	9.6	/	8.817	/	/
			kg/h	0.033	0.039	0.036	0.033	0.035	0.04	/	0.036	/	/
1													
DA027		/	Nm <sup>3</sup> /h	4690	4846	4569	4809	4582	4478	/	4662.333	/	/

1	mg/m <sup>3</sup>	2.8	2	1.7	1.5	2.3	2.1	/	2.067	20	
	kg/h	0.013	0.01	7.77×10 <sup>-3</sup>	7.21×10 <sup>-3</sup>	0.011	9.40×10 <sup>-3</sup>	74.36%	0.009	1	
			<b>2025.8.14</b>				<b>2025.8.15</b>				
/	Nm <sup>3</sup> /h	6504	5674	5972	5923	6231	5477	/	5963.5	/	/
/	%	4.8	4.6	4.3	4.7	4.5	4.6	/	4.583	/	/

DA001

£„D;>^ \2 n9 „ .o q λ' b •( σ:#λ q v B„ ϕ — M \X n.b b „ .o q%q .o q y0 2 2, —

DA006		/	Nm <sup>3</sup> /h	1025	1003	994	959	1043	1021	/	1007.5	/	/
		/	%	4.6	3.3	3.3	3.2	3.5	4.8	/	3.783	/	/
			mg/m <sup>3</sup>	0.335	0.32	0.313	0.312	0.305	0.29	/	0.313	/	/
			mg/m <sup>3</sup>	0.368	0.325	0.318	0.316	0.314	0.322	/	0.327	/	/
			kg/h	3.43×10 <sup>-4</sup>	3.21×10 <sup>-4</sup>	3.11×10 <sup>-4</sup>	2.99×10 <sup>-4</sup>	3.18×10 <sup>-4</sup>	2.96×10 <sup>-4</sup>	/	3.15×10 <sup>-4</sup>	5.2	
			mg/m <sup>3</sup>	3.77	3.95	3.87	3.91	4.01	4.08	/	3.932	/	/
			mg/m <sup>3</sup>	4.1	4	3.9	4	4.1	4.5	/	4.1	/	/
			kg/h	3.86×10 <sup>-3</sup>	3.96×10 <sup>-3</sup>	3.85×10 <sup>-3</sup>	3.75×10 <sup>-3</sup>	4.18×10 <sup>-3</sup>	4.17×10 <sup>-3</sup>	/	0.004	75	
			mg/m <sup>3</sup>	16	19	26	36	28	25	/	25	/	/
			mg/m <sup>3</sup>	18	21	29	41	32	28	/	28.167	10	0
			kg/h	0.016	0.019	0.026	0.035	0.029	0.026	/	0.025	1.4	
			mg/m <sup>3</sup>	63	72	71	75	72	70	/	70.5	/	/
			mg/m <sup>3</sup>	69	80	80	84	81	78	/	78.667	10	0
			kg/h	0.065	0.072	0.071	0.072	0.075	0.071	/	0.071	0.4	7
	DA010 3#		/	Nm <sup>3</sup> /h	8602	8502	8472	8574	8564	8491	/	8534.167	/
			mg/m <sup>3</sup>	7	8.1	7.4	8.5	9.1	7.2	/	7.883	/	/
			kg/h	0.06	0.069	0.063	0.073	0.078	0.061	/	0.067	/	/
DA010 3#		/	Nm <sup>3</sup> /h	10142	9865	10639	10015	10763	10315	/	10289.833	/	/
			mg/m <sup>3</sup>	2.3	3.5	1.9	2.6	2	3.1	/	2.567	20	
			kg/h	0.023	0.035	0.02	0.026	0.022	0.032	60.89%	0.026	1	
DA024 1#		/	Nm <sup>3</sup> /h	1957	2029	1950	2099	2021	2022	/	2013	/	/
			mg/m <sup>3</sup>	1.7	2.2	2.7	2	2.5	1.5	/	2.1	20	
			kg/h	3.33×10 <sup>-3</sup>	4.46×10 <sup>-3</sup>	5.27×10 <sup>-3</sup>	4.20×10 <sup>-3</sup>	5.05×10 <sup>-3</sup>	3.03×10 <sup>-3</sup>	/	0.004	1	

A025 2#	/	Nm <sup>3</sup> /h	2967	2873	2867	2864	2929	2941		2906.833	/	/
		mg/m <sup>3</sup>	1.6	1.4	2.1	1.5	2	1.2		1.633	20	
		kg/h	4.75×10 <sup>-3</sup>	4.02×10 <sup>-3</sup>	6.02×10 <sup>-3</sup>	4.28×10 <sup>-3</sup>	5.86×10 <sup>-3</sup>	3.24×10 <sup>-3</sup>		0.005	1	
DA026 3#	/	Nm <sup>3</sup> /h	14235	14122	14355	14032	13945	14260	/	14158.167	/	/
		mg/m <sup>3</sup>	1.8	1.5	1.2	1.1	1.4	1.6	/	1.433	20	
		kg/h	0.026	0.021	0.017	0.015	0.02	0.023	/	0.02	1	
DA029	/	Nm <sup>3</sup> /h	1966	1886	1962	1969	1890	2043	/	1952.667	/	/
		mg/m <sup>3</sup>	47.6	49.2	46.5	46.2	48.7	44	/	47.033	/	/
		kg/h	0.094	0.093	0.091	0.091	0.092	0.09	/	0.092	/	/
3 DA029	/	Nm <sup>3</sup> /h	1794	1623	1622	1806	1633	1636	/	1685.667	/	/
		mg/m <sup>3</sup>	1.9	2.7	3	2.4	2.7	1.7	/	2.4	20	
		kg/h	3.41×10 <sup>-3</sup>	4.38×10 <sup>-3</sup>	4.87×10 <sup>-3</sup>	4.33×10 <sup>-3</sup>	4.41×10 <sup>-3</sup>	2.78×10 <sup>-3</sup>	95.61%	0.004	1	
DA038	/	Nm <sup>3</sup> /h	4463	4629	4564	4561	4588	4473	/	4546.333	/	/
		mg/m <sup>3</sup>	9.7	8.5	7.9	8.4	7.7	9.3	/	8.583	/	/
		kg/h	0.043	0.039	0.036	0.038	0.035	0.042	/	0.039	/	/
DA038	/	Nm <sup>3</sup> /h	4405	4298	4419	4289	4414	4193	/	4336.333	/	/
		mg/m <sup>3</sup>	2.4	2	1.4	1.6	1.9	2.1	/	1.9	20	
		kg/h	0.011	8.60×10 <sup>-3</sup>	6.19×10 <sup>-3</sup>	6.86×10 <sup>-3</sup>	8.39×10 <sup>-3</sup>	8.81×10 <sup>-3</sup>	78.56%	0.008	1	
			<b>2025.8.16</b>				<b>2025.8.17</b>					
DA009 2#	/	Nm <sup>3</sup> /h	18592	20877	18731	19021	18575	17460	/	18876	/	/
		mg/m <sup>3</sup>	28.7	28.3	32.6	29.7	32.7	32.2	/	30.700	/	/
		kg/h	0.534	0.591	0.611	0.565	0.607	0.562	/	0.578	/	/
DA009 2#	/	Nm <sup>3</sup> /h	18825	19044								

			mg/m <sup>3</sup>	1.2	1.3	1.8	1.4	1.7	1.1	/	1.417	20	
			kg/h	0.023	0.025	0.031	0.024	0.031	0.021	95.53%	0.026	1	
DA017		/	Nm <sup>3</sup> /h	2692	2596	2645	2420	2520	2577	/	2575	/	/
			mg/m <sup>3</sup>	92.8	98.7	91.8	97.4	94.6	86.5	/	93.633	/	/
			kg/h	0.25	0.256	0.243	0.236	0.238	0.223	/	0.241	/	/
DA017		/	Nm <sup>3</sup> /h	2803	2769	2862	2868	2709	2830	/	2806.833	/	/
			mg/m <sup>3</sup>	1.6	2.9	1.5	2.1	2.5	1.9	/	2.083	20	
			kg/h	4.48×10 <sup>-3</sup>	8.03×10 <sup>-3</sup>	4.29×10 <sup>-3</sup>	6.02×10 <sup>-3</sup>	6.77×10 <sup>-3</sup>	5.38×10 <sup>-3</sup>	97.58%	0.006	1	
DA018		/	Nm <sup>3</sup> /h	2530	2484	2585	2577	2631	2576	/	2563.833	/	/
			mg/m <sup>3</sup>	44.6	39	39.8	42.5	46.2	40.7	/	42.133	/	/
			kg/h	0.113	0.097	0.103	0.11	0.122	0.105	/	0.108	/	/
DA018		/	Nm <sup>3</sup> /h	2948	2734	2939	2856	2766	2705	/	2824.667	/	/
			mg/m <sup>3</sup>	1.5	2.3	1.5	1.3	1.8	2.4	/	1.8	20	
			kg/h	4.42×10 <sup>-3</sup>	6.29×10 <sup>-3</sup>	4.41×10 <sup>-3</sup>	3.71×10 <sup>-3</sup>	4.98×10 <sup>-3</sup>	6.49×10 <sup>-3</sup>	95.34%	0.005	1	
DA019		/	Nm <sup>3</sup> /h	2406	2512	2472	2418	2492	2454	/	2459	/	/
			mg/m <sup>3</sup>	210	195	194	201	204	195	/	199.833	/	/
			kg/h	0.505	0.49	0.48	0.486	0.508	0.479	/	0.491	/	/
DA019		/	Nm <sup>3</sup> /h	2703	2571	2665	2595	2525	2689	/	2624.667	/	/
			mg/m <sup>3</sup>	8.6	9.4	9.8	8.9	8.2	9.1	/	9	20	
			kg/h	0.023	0.024	0.026	0.023	0.021	0.024	95.22%	0.024	1	
DA028		/	Nm <sup>3</sup> /h	2382	2107	2173	2317	2248	2307	/	2255.667	/	/
			mg/m <sup>3</sup>	43.8	47.5	46	44.7	48.5	48.4	/	46.483	/	/
	2		kg/h	0.104	0.1	0.1	0.104	0.109	0.112	/	0.105	/	/
DA028		/	Nm <sup>3</sup> /h	2391	2341	2290	2045	2336	2389	/	2298.667	/	/
			mg/m <sup>3</sup>	1.3	1.8	2.2	1.9	1.5	2.3	/	1.833	20	
			kg/h	3.11×10 <sup>-3</sup>	4.21×10 <sup>-3</sup>	5.04×10 <sup>-3</sup>	3.89×10 <sup>-3</sup>	3.50×10 <sup>-3</sup>	5.49×10 <sup>-3</sup>	95.99%	0.004	1	

2														
DA039	NMHC	/	Nm <sup>3</sup> /h	17362	17293	17242	16621	16654	16721	/	16982.167	/	/	
			mg/m <sup>3</sup>	0.31	0.32	0.4	0.28	0.34	0.54	/	0.365	60		
			kg/h	5.38×10 <sup>-3</sup>	5.53×10 <sup>-3</sup>	6.90×10 <sup>-3</sup>	4.65×10 <sup>-3</sup>	5.66×10 <sup>-3</sup>	9.03×10 <sup>-3</sup>	/	0.006	3		
DA040	NMHC	/	Nm <sup>3</sup> /h	42	49	44	43	44	42	/	44	/	/	
			mg/m <sup>3</sup>	0.86	0.84	1	0.79	0.8	0.71	/	0.833	60		
			kg/h	3.61×10 <sup>-5</sup>	4.12×10 <sup>-5</sup>	4.40×10 <sup>-5</sup>	3.40×10 <sup>-5</sup>	3.52×10 <sup>-5</sup>	2.98×10 <sup>-5</sup>	/	3.67×10 <sup>-5</sup>	3		
			mg/m <sup>3</sup>	21.1	21.2	16.7	21.3	18.9	12.9	/	18.683	60		
		kg/h	8.86×10 <sup>-4</sup>	1.04×10 <sup>-3</sup>	7.35×10 <sup>-4</sup>	9.16×10 <sup>-4</sup>	8.32×10 <sup>-4</sup>	5.42×10 <sup>-4</sup>	/	0.001	3.6			
				<b>2025.8.18</b>				<b>2025.8.19</b>						
DA041	NMHC	/	Nm <sup>3</sup> /h	3744	3654	3856	3891	3972	3887	/	3834	/	/	
			mg/m <sup>3</sup>	0.49	0.53	0.47	0.51	0.46	0.54	/	0.5	/	/	
			kg/h	1.83×10 <sup>-3</sup>	1.94×10 <sup>-3</sup>	1.81×10 <sup>-3</sup>	1.98×10 <sup>-3</sup>	1.83×10 <sup>-3</sup>	2.10×10 <sup>-3</sup>	/	0.002	4.9		
			mg/m <sup>3</sup>	0.39	0.42	0.38	0.58	0.52	0.46	/	0.458	60		
			kg/h	1.46×10 <sup>-3</sup>	1.53×10 <sup>-3</sup>	1.47×10 <sup>-3</sup>	2.26×10 <sup>-3</sup>	2.07×10 <sup>-3</sup>	1.79×10 <sup>-3</sup>	/	0.002	3		
		mg/m <sup>3</sup>	N ` n											

			kg/h							/	/	/	/	
DA043		/	Nm <sup>3</sup> /h	590	600	593	563	582	604	/	588.667	/	/	
			mg/m <sup>3</sup>	ND	ND	ND	ND	ND	ND	/	/	/	/	
			kg/h							/	/	4.9		
	NMHC			mg/m <sup>3</sup>	0.42	0.45	0.52	0.39	0.34	0.41	/	0.422	60	
				kg/h	2.48×10 <sup>-4</sup>	2.70×10 <sup>-4</sup>	3.08×10 <sup>-4</sup>	2.20×10 <sup>-4</sup>	1.98×10 <sup>-4</sup>	2.48×10 <sup>-4</sup>	50.81%	2.49×10 <sup>-4</sup>	3	
				mg/m <sup>3</sup>	ND	ND	ND	ND	ND	ND	/	/	50	
			kg/h							/	/	1.8		
DA044		/	Nm <sup>3</sup> /h	655	663	642	661	646	667	/	655.667	/	/	
			mg/m <sup>3</sup>	0.35	0.38	0.36	0.41	0.39	0.42	/	0.385	/	/	
			kg/h	2.29×10 <sup>-4</sup>	2.52×10 <sup>-4</sup>	2.31×10 <sup>-4</sup>	2.71×10 <sup>-4</sup>	2.52×10 <sup>-4</sup>	2.80×10 <sup>-4</sup>	/	2.52×10 <sup>-4</sup>	/	/	
	NMHC			mg/m <sup>3</sup>	0.91	0.92	0.9	1.24	1.14	1.19	/	1.05	/	/
				kg/h	5.96×10 <sup>-4</sup>	6.10×10 <sup>-4</sup>	5.78×10 <sup>-4</sup>	8.20×10 <sup>-4</sup>	7.36×10 <sup>-4</sup>	7.94×10 <sup>-4</sup>	/	0.001	/	/
				mg/m <sup>3</sup>	ND	ND	ND	ND	ND	ND	/	/	/	/
			kg/h							/	/	/	/	
DA044		/	Nm <sup>3</sup> /h	764	765	766	769	757	742	/	760.500	/	/	
			mg/m <sup>3</sup>	0.27	0.29	0.26	0.26	0.28	0.3	/	0.277	/	/	
			kg/h	2.06×10 <sup>-4</sup>	2.22×10 <sup>-4</sup>	1.99×10 <sup>-4</sup>	2.00×10 <sup>-4</sup>	2.12×10 <sup>-4</sup>	2.23×10 <sup>-4</sup>	16.67%	2.10×10 <sup>-4</sup>	4.9		
	NMHC			mg/m <sup>3</sup>	0.42	0.25	0.33	0.45	0.41	0.46	/	0.387	60	
				kg/h	3.21×10 <sup>-4</sup>	1.91×10 <sup>-4</sup>	2.53×10 <sup>-4</sup>	3.46×10 <sup>-4</sup>	3.10×10 <sup>-4</sup>	3.41×10 <sup>-4</sup>	57.33%	2.94×10 <sup>-4</sup>	3	
				mg/m <sup>3</sup>	ND	ND	ND	ND	ND	ND	/	/	50	
			kg/h							/	/	1.8		
DA047		/	Nm <sup>3</sup> /h	659	651	672	665	643	658	/	658	/	/	
			mg/m <sup>3</sup>	0.62	0.64	0.68	0.68	0.59	0.54	/	0.625	/	/	
			kg/h	4.09×10 <sup>-4</sup>	4.17×10 <sup>-4</sup>	4.57×10 <sup>-4</sup>	4.52×10 <sup>-4</sup>	3.79×10 <sup>-4</sup>	3.55×10 <sup>-4</sup>	/	4.12×10 <sup>-4</sup>	/	/	
	NMHC		mg/m <sup>3</sup>	0.59	0.65	0.67	1.15	1.26	1.19	/	0.918	/	/	

		kg/h	3.89×10 <sup>-4</sup>	4.23×10 <sup>-4</sup>	4.50×10 <sup>-4</sup>	7.65×10 <sup>-4</sup>	8.10×10 <sup>-4</sup>	7.83×10 <sup>-4</sup>	/	0.001	/	/
		mg/m <sup>3</sup>	ND	ND	ND	ND	ND	ND	/	/	/	/
		kg/h							/	/	/	/
	/	Nm <sup>3</sup> /h	710	689	697	671	681	692	/	690	/	/
		mg/m <sup>3</sup>	0.5	0.46	0.49	0.44	0.43	0.46	/	0.463	/	/
DA047		kg/h	3.55×10 <sup>-4</sup>	3.17×10 <sup>-4</sup>	3.42×10 <sup>-4</sup>	2.95×10 <sup>-4</sup>	2.93×10 <sup>-4</sup>	3.18×10 <sup>-4</sup>	22.33%	3.2×10 <sup>-4</sup>	4.9	
	NMHC	mg/m <sup>3</sup>	0.33	0.39	0.36	0.35	0.41	0.36	/	0.367	60	
		kg/h	2.34×10 <sup>-4</sup>	2.69×10 <sup>-4</sup>	2.51×10 <sup>-4</sup>	2.35×10 <sup>-4</sup>	2.79×10 <sup>-4</sup>	2.49×10 <sup>-4</sup>	/	2.52×10 <sup>-4</sup>	3	
		mg/m <sup>3</sup>	ND	ND	ND	ND	ND	ND	/	/	50	
		kg/h							/	/	1.8	
	/	Nm <sup>3</sup> /h	712	713	738	684	709	658	/	702.333	/	/
		mg/m <sup>3</sup>	0.45	0.42	0.44	0.46	0.5	0.47	/	0.457	/	/
DA050		kg/h	3.20×10 <sup>-4</sup>	2.99×10 <sup>-4</sup>	3.25×10 <sup>-4</sup>	3.15×10 <sup>-4</sup>	3.55×10 <sup>-4</sup>					

∩

	NMHC		mg/m <sup>3</sup>	0.47	0.44	0.45	0.46	0.48	0.49	/	0.465	/	/	
			kg/h	4.06×10 <sup>-4</sup>	3.70×10 <sup>-4</sup>	3.94×10 <sup>-4</sup>	3.72×10 <sup>-4</sup>	4.25×10 <sup>-4</sup>	4.18×10 <sup>-4</sup>	4.18×10 <sup>-4</sup>	/	3.95×10 <sup>-4</sup>	4.9	
			mg/m <sup>3</sup>	0.55	0.84	0.6	0.58	0.54	0.49	/	0.6	60		
			kg/h	4.75×10 <sup>-4</sup>	7.07×10 <sup>-4</sup>	5.26×10 <sup>-4</sup>	4.69×10 <sup>-4</sup>	4.78×10 <sup>-4</sup>	4.18×10 <sup>-4</sup>	/	0.003	3		
			mg/m <sup>3</sup>	ND	ND	ND	ND	ND	ND	/	/	50		
			kg/h							/	/	1.8		
DA053	NMHC	/	Nm <sup>3</sup> /h	827	837	856	847	847	863	/	846.167	/	/	
			mg/m <sup>3</sup>	0.67	0.68	0.7	0.74	0.73	0.76	/	0.713	/	/	
			kg/h	5.54×10 <sup>-4</sup>	5.69×10 <sup>-4</sup>	5.99×10 <sup>-4</sup>	6.27×10 <sup>-4</sup>	6.18×10 <sup>-4</sup>	6.56×10 <sup>-4</sup>	/	0.001	4.9		
			mg/m <sup>3</sup>	1.61	1.23	1.74	1.1	1.16	1.04	/	1.313	60		
			kg/h	1.33×10 <sup>-3</sup>	1.03×10 <sup>-3</sup>	1.49×10 <sup>-3</sup>	9.32×10 <sup>-4</sup>	9.83×10 <sup>-4</sup>	8.98×10 <sup>-4</sup>	/	0.001	3		
			mg/m <sup>3</sup>	8.74	6.47	5.5	ND	ND	ND	/	/	50		
DA053	NMHC		kg/h	7.23×10 <sup>-3</sup>	5.42×10 <sup>-3</sup>	4.71×10 <sup>-3</sup>				/	/	1.8		
		/	Nm <sup>3</sup> /h	798	797	810	769	830	830	/	805.667	/	/	
			mg/m <sup>3</sup>	0.47	0.44	0.48	0.5	0.46	0.49	/	0.473	/	/	
			kg/h	3.75×10 <sup>-4</sup>	3.51×10 <sup>-4</sup>	3.89×10 <sup>-4</sup>	3.85×10 <sup>-4</sup>	3.82×10 <sup>-4</sup>	4.07×10 <sup>-4</sup>	36.82%	0.000	4.9		
			mg/m <sup>3</sup>	0.57	0.38	0.63	0.69	0.82	0.57	/	0.610	60		
			kg/h	4.55×10 <sup>-4</sup>	3.03×10 <sup>-4</sup>	5.10×10 <sup>-4</sup>	5.31×10 <sup>-4</sup>	6.81×10 <sup>-4</sup>	4.73×10 <sup>-4</sup>	55.70%	4.92×10 <sup>-4</sup>	3		
DA013	NMHC		mg/m <sup>3</sup>	ND	ND	ND	ND	ND	ND	/	/	50		
			kg/h							/	/	1.8		
DA013	NMHC	/	Nm <sup>3</sup> /h	5095	5482	5798	5190	5393	5096		5342.333	/	/	
			mg/m <sup>3</sup>	0.42	0.45	0.4	0.46	0.44	0.47	/	0.44	/	/	
			kg/h	2.14×10 <sup>-3</sup>	2.47×10 <sup>-3</sup>	2.32×10 <sup>-3</sup>	2.39×10 <sup>-3</sup>	2.37×10 <sup>-3</sup>	2.40×10 <sup>-3</sup>	/	0.002	35		

DA015	/	Nm <sup>3</sup> /h	17962	17603	17356	17176	17562	17820	/	17579.833	/	/	
		mg/m <sup>3</sup>	76.5	78.3	77.4	83.1	81.6	79.3	/	79.367	/	/	
		kg/h	1.374	1.378	1.343	1.427	1.433	1.413	/	1.395	/	/	
DA015	/	Nm <sup>3</sup> /h	28663	28693	28236	28379	28198	28183	/	28392	/	/	
		mg/m <sup>3</sup>	140	144	137	145	150	148	/	144	/	/	
		kg/h	4.013	4.132	3.868	4.115	4.23	4.171	/	4.088	/	/	
DA015	/	Nm <sup>3</sup> /h	51055	51777	51595	51171	50835	50293	/	51121	/	/	
		mg/m <sup>3</sup>	15.9	15.3	16	16.5	16.2	15.7	/	15.933	/	/	
		kg/h	0.812	0.792	0.826	0.844	0.824	0.79	85.14%	0.815	35		
DA020	/	Nm <sup>3</sup> /h	6117	5919	5866	5957	5869	5746	/	5912.333	/		
		mg/m <sup>3</sup>	2.9	2.5	1.9	1.7	2.3	2.6	/	2.317	20		
		kg/h	0.018	0.015	0.011	0.01	0.013	0.015	/	0.014	1		
				<b>2025.8.22</b>			<b>2025.8.23</b>						
DA007	/	Nm <sup>3</sup> /h	18684	18240	18835	19405	18093	18767	/	18670.667	/	/	
		mg/m <sup>3</sup>	2.6	2.4	1.7	1.5	2.1	2.8	/	2.183	10		
		kg/h	0.049	0.044	0.032	0.029	0.038	0.053	/	0.041	1		
DA012	/	Nm <sup>3</sup> /h	8883	8913	8597	8661	7904	7546	/	8417.333	/	/	
		mg/m <sup>3</sup>	3	2.1	2.6	2.2	2.7	1.7	/	2.383	20		
		kg/h	0.027	0.019	0.022	0.019	0.021	0.013	/	0.02	1		
DA014	/	Nm <sup>3</sup> /h	12467	12994	12867	13401	12606	12837	/	12862	/	/	
		mg/m <sup>3</sup>	11.8	11.1	10.9	12.4	12.2	11.9	/	11.717	/	/	
		kg/h	0.147	0.144	0.14	0.166	0.154	0.153	/	0.151	35		
DA021	/	Nm <sup>3</sup> /h	3748	3910	3988	4212	4246	4084	/	4031.333	/	/	
		mg/m <sup>3</sup>	1.4	1.9	2.1	1.7	1.1	2.3	/	1.75	20		

			kg/h	5.25×10 <sup>-3</sup>	7.43×10 <sup>-3</sup>	8.37×10 <sup>-3</sup>	7.16×10 <sup>-3</sup>	4.67×10 <sup>-3</sup>	9.39×10 <sup>-3</sup>	/	0.007	1			
DA032		/	Nm <sup>3</sup> /h	21963	22239	22373	21705	22055	21867	/	22033.667	/	/		
			mg/m <sup>3</sup>	7.6	8.4	7.3	6.9	6	8.1	/	7.383	/	/		
			kg/h	0.167	0.187	0.163	0.15	0.132	0.177	/	0.163	/	/		
DA032		/	Nm <sup>3</sup> /h	25146	27057	25357	26332	26784	26615	/	26215.167	/	/		
			mg/m <sup>3</sup>	1.9	1.4	2.2	1.7	2.4	1.2	/	1.8	20			
			kg/h	0.048	0.038	0.056	0.045	0.064	0.032	71.00%	0.047	1			
DA033		/	Nm <sup>3</sup> /h	15919	15704	16292	15783	15971	15650	/	15886.5	/	/		
			mg/m <sup>3</sup>	8	7.3	8.7	6.9	7.8	8.4	/	7.85	/	/		
			kg/h	0.127	0.115	0.142	0.109	0.125	0.131	/	0.125	/	/		
DA033		/	Nm <sup>3</sup> /h	17712	17946	18577	18318	18213	17374	/	18023.333	/	/		
			mg/m <sup>3</sup>	2.8	1.8	2.1	1.6	1.7	2.5	/	2.083	20			
			kg/h	0.05	0.032	0.039	0.029	0.031	0.043	70.09%	0.037	1			
				<b>2025.8.24</b>						<b>2025.8.25</b>					
DA011		/	Nm <sup>3</sup> /h	16102	16699	17590	17428	16463	16431	/	16785.5	/	/		
			mg/m <sup>3</sup>	38.2	36.7	37.9	37.4	39	36.5	/	37.617	/	/		
			kg/h	0.615	0.613	0.667	0.652	0.642	0.6	/	0.632	8.7			
DA022		/	Nm <sup>3</sup> /h	10326	10425	10194	10154	10587	10328	/	10335.667	/	/		
			mg/m <sup>3</sup>	33.9	35.9	34.7	36.4	33.8	36.1	/	35.133	/	/		
			kg/h	0.35	0.374	0.354	0.37	0.358	0.373	/	0.363	/	/		
DA022		/	Nm <sup>3</sup> /h	13332	12911	12886	13019	13564	13499	/	13201.833	/	/		

mg/m <sup>3</sup>	1.9	1.7	1.3	1.1	1.5	2.1	/	1.6	20
kg/h	0.025	0.022	0.017	0.014	0.02	0.028	94.22%	0.021	1

DA030

			kg/h	12.1	11.4	12	10.4	10.4	10.2	/	11.083	8.7				
DA037		/	Nm <sup>3</sup> /h	678	692	671	677	686	658	/	677	/	/			
			mg/m <sup>3</sup>	47.3	45.2	49.2	50.4	48.1	51.7	/	48.65	/	/			
			kg/h	0.032	0.031	0.033	0.034	0.033	0.034	/	0.033	8.7				
				<b>2025.11.3</b>						<b>2025.11.4</b>						
DA016		/	Nm <sup>3</sup> /h	42258	44524	42024	41353	42038	43086	/	42547.167	/	/			
			mg/m <sup>3</sup>	51.5	60.8	54.5	56.9	53.7	57.7	/	55.85	/	/			
			kg/h	2.18	2.71	2.29	2.35	2.26	2.49	/	2.38	8.7				
DA035		/	Nm <sup>3</sup> /h	2309	2315	2317	2655	2305	2307	/	2368	/	/			
			mg/m <sup>3</sup>	9.37	10.4	8.96	11.1	9.81	10.8	/	10.073	/	/			
			kg/h	0.022	0.024	0.021	0.029	0.023	0.025	/	0.024	20				
DA036		/	Nm <sup>3</sup> /h	3773	3527	3548	3771	3773	3277	/	3611.5	/	/			
			mg/m <sup>3</sup>	63.2	73.9	70	56	65.7	63.3	/	0.002	/	/			
			kg/h	0.238	0.261	0.248	0.211	0.248	0.207	/	0.236	20				
DA054		/	Nm <sup>3</sup> /h	9701	9313	9231	9271	9150	9462	/	9354.667	/	/			
			mg/m <sup>3</sup>	8.16	9.83	9.24	8.67	8.43	9.22	/	8.925	/	/			
			kg/h	0.079	0.092	0.085	0.08	0.077	0.087	/	0.083	/	/			
		NMHC		mg/m <sup>3</sup>	14.1	14.9	12.6	13.8	14.8	13.1	/	13.883	/	/		
			kg/h	0.137	0.139	0.116	0.128	0.135	0.124	/	0.13	/	/			
			mg/m <sup>3</sup>	10.5	11.3	12.1	11.8	10.1	11.4	/	11.2	/	/			
		kg/h	0.102	0.105	0.112	0.109	0.092	0.108	/	0.105	/	/				

DA054		/	Nm <sup>3</sup> /h	2039	2018	2003	2023	1994	2002	/	2013.167	/	/	
			mg/m <sup>3</sup>	9.41	9.29	9.74	11.4	10.3	11.7	/	10.307	/	/	
			kg/h	0.019	0.019	0.02	0.023	0.021	0.023	/	0.021	/	/	
	NMHC			mg/m <sup>3</sup>	12.8	11.9	13.8	14.1	14.3	14.6	/	13.583	/	/
				kg/h	0.026	0.024	0.028	0.029	0.029	0.029	/	0.028	/	/
				mg/m <sup>3</sup>	16.3	17.6	18.6	16.5	18.7	15.1	/	17.133	/	/
			kg/h	0.033	0.036	0.037	0.033	0.037	0.03	/	0.034	/	/	
DA054		/	Nm <sup>3</sup> /h	13362	13638	13543	11849	11956	12261	/	12768.167	/	/	
			mg/m <sup>3</sup>	1.1	1.13	1.06	1.32	1.45	1.41	/	1.245	/	/	
			kg/h	0.015	0.015	0.014	0.016	0.017	0.017	84.96%	0.016	4.9		
	NMHC			mg/m <sup>3</sup>	8.02	7.17	6.29	6.54	6.69	6.38	/	6.848	60	
				kg/h	0.107	0.098	0.085	0.077	0.08	0.078	44.39%	0.088	3	
				mg/m <sup>3</sup>	0.914	0.836	0.816	0.844	0.891	0.854	/	0.859	/	/
			kg/h	0.012	0.011	0.011	0.01	0.011	0.01	92.21%	0.011	0.3 3		

2mg/m<sup>3</sup>

0.25mg/m<sup>3</sup>

DA001

DB32/ 4385-2022

DA002

GB14554-93 2

GB31571-2015 6 NMHC

DB32/4041-2021 1

DA003~DA005

DA008~DA010

DA012

DA023

DA017~DA019

DA022 DA034

DA032 DA033 1#~3#

DA024~DA026

1~3 DA027~DA029

DA020

DA021 DA030 DA031

DA038

DB32/4041-2021

1

DA007 GB31573-2015 4 DA011 DA013~DA016 DA035~DA037  
 GB14554-93 2 DA040 DB32/3151-2016  
 1 DA039 NMHC DB32/4041-2021 1 DA040 DA041 DA043  
 DA044 DA047 DA050 DA052 DA053 GB14554-93 2 NMHC  
 DB32/4041-2021 1 DA054 GB14554-93  
 2 NMHC DB32/4041-2021 1  
 85.14% 60.86%~97.58%  
 16.67% 22.33% 36.82% NMHC 50.81% 55.70% 57.33%  
 NMHC 84.96% 92.21% 44.39%  
 2

9.2.1-2

9.2.1-2

mg/m<sup>3</sup>

	2025.08.24	1#	mg/m <sup>3</sup>	0.253	0.233	0.275	0.275	0.5	
		2#	mg/m <sup>3</sup>	0.344	0.373	0.324	0.373	0.5	
		3#	mg/m <sup>3</sup>	0.344	0.385	0.41	0.41	0.5	
		4#	mg/m <sup>3</sup>	0.296	0.321	0.307	0.321	0.5	
		1#	mg/m <sup>3</sup>	ND	ND	ND	/	1	
		2#	mg/m <sup>3</sup>	ND	ND	ND	/	1	

	2025.08.25	3#	mg/m <sup>3</sup>	ND	ND	ND	/	1	
		4#	mg/m <sup>3</sup>	ND	ND	ND	/	1	
		1#	mg/m <sup>3</sup>	0.06	0.04	0.07	0.07	1.5	
		2#	mg/m <sup>3</sup>	0.11	0.08	0.1	0.11	1.5	
		3#	mg/m <sup>3</sup>	0.19	0.17	0.19	0.19	1.5	
		4#	mg/m <sup>3</sup>	0.11	0.14	0.13	0.14	1.5	
		1#	mg/m <sup>3</sup>	ND	ND	ND	/	0.05	
		2#	mg/m <sup>3</sup>	0.026	0.027	0.029	0.029	0.05	
		3#	mg/m <sup>3</sup>	0.043	0.045	0.044	0.045	0.05	
		4#	mg/m <sup>3</sup>	0.037	0.033	0.033	0.037	0.05	
		1#	mg/m <sup>3</sup>	0.4	0.35	0.32	0.4	4	
		2#	mg/m <sup>3</sup>	0.53	0.51	0.49	0.53	4	
		3#	mg/m <sup>3</sup>	0.59	0.56	0.55	0.59	4	
		4#	mg/m <sup>3</sup>	0.5	0.64	0.5	0.64	4	
		5#	mg/m <sup>3</sup>	0.76	0.77	0.73	0.77	6	
		1#	mg/m <sup>3</sup>	0.005	0.005	0.005	0.005	0.06	
		2#	mg/m <sup>3</sup>	0.006	0.006	0.007	0.007	0.06	
		3#	mg/m <sup>3</sup>	0.006	0.007	0.007	0.007	0.06	
		4#	mg/m <sup>3</sup>	0.007	0.006	0.006	0.007	0.06	
		1#	mg/m <sup>3</sup>	0.23	0.207	0.243	0.243	0.5	
	2#	mg/m <sup>3</sup>	0.316	0.382	0.348	0.382	0.5		
	3#	mg/m <sup>3</sup>	0.37	0.405	0.382	0.405	0.5		
	4#	mg/m <sup>3</sup>	0.31	0.347	0.324	0.347	0.5		
	1#	mg/m <sup>3</sup>	ND	ND	ND	/	1		

		2#	mg/m <sup>3</sup>	ND	ND	ND	/	1	
		3#	mg/m <sup>3</sup>	ND	ND	ND	/	1	
		4#	mg/m <sup>3</sup>	ND	ND	ND	/	1	
		1#	mg/m <sup>3</sup>	0.03	0.05	0.02	0.05	1.5	
		2#	mg/m <sup>3</sup>	0.07	0.09	0.11	0.11	1.5	
		3#	mg/m <sup>3</sup>	0.14	0.17	0.18	0.18	1.5	
		4#	mg/m <sup>3</sup>	0.15	0.14	0.12	0.15	1.5	
		1#	mg/m <sup>3</sup>	ND	ND	ND	/	0.05	
		2#	mg/m <sup>3</sup>	0.029	0.029	0.028	0.029	0.05	
		3#	mg/m <sup>3</sup>	0.047	0.045	0.045	0.047	0.05	
		4#	mg/m <sup>3</sup>	0.037	0.035	0.034	0.037	0.05	
		1#	mg/m <sup>3</sup>	0.32	0.37	0.33	0.37	4	
		2#	mg/m <sup>3</sup>	0.62	0.66	0.59	0.66	4	
		3#	mg/m <sup>3</sup>	0.47	0.42	0.45	0.47	4	
		4#	mg/m <sup>3</sup>	0.57	0.48	0.53	0.57	4	
		5#	mg/m <sup>3</sup>	0.72	0.78	0.74	0.78	6	
		1#	mg/m <sup>3</sup>	0.004	0.004	0.004	0.004	0.06	
		2#	mg/m <sup>3</sup>	0.007	0.006	0.007	0.007	0.06	
		3#	mg/m <sup>3</sup>	0.006	0.007	0.006	0.007	0.06	
		4#	mg/m <sup>3</sup>	0.006	0.006	0.006	0.006	0.06	

0.5mg/m<sup>3</sup>

0.02mg/m<sup>3</sup>

0.41mg/m<sup>3</sup>

0.047mg/m<sup>3</sup>

0.66mg/m<sup>3</sup>

DB32/4041-2021 3 0.5mg/m<sup>3</sup> 0.05mg/m<sup>3</sup> 4mg/m<sup>3</sup> 0.19mg/m<sup>3</sup>  
0.007mg/m<sup>3</sup> GB14554-93 1 1.5mg/m<sup>3</sup> 0.06mg/m<sup>3</sup>  
DB32/3151-2016 2 1mg/m<sup>3</sup>  
0.78mg/m<sup>3</sup> DB32/4041-2021 2 6mg/m<sup>3</sup>

## 9.2.2

### 9.2.2-1

#### 9.2.2-1

			2025.8.26				2025.8.27							
W1	pH		8.7	8.6	8.6	8.7	8.6	8.4	8.6	8.5	8.5875	/	/	/
		mg/L	28	25	32	26	22	26	24	27	26.25	/	/	/
		mg/L	15	20	18	14	17	23	19	16	17.75	/	/	/
	TDS	mg/L	986	864	938	1080	948	831	882	1010	942.375	/	/	/
W2	pH		7.3	7.3	7.4	7.3	7.3	7.2	7.2	7.3	7.2875	/	6.5~9.0	
		mg/L	10	12	11	9	12	13	14	12	11.625	/	50	
		mg/L	6	5	6	7	8	6	7	6	6.375	/	/	/
	TDS	mg/L	40	49	39	40	47	42	37	40	41.75	/	/	/
W3	pH		8.6	8.6	8.5	8.5	8.5	8.5	8.5	8.6	8.5375	/	/	/
		mg/L	227	250	266	229	262	223	245	239	242.625	/	/	/
		mg/L	57	46	66	54	59	50	63	56	56.375	/	/	/
		mg/L	182	175	192	171	176	184	170	194	180.5	/	/	/

			2025.8.26				2025.8.27							
		mg/L	0.89	0.93	0.9	0.85	0.98	1.02	0.98	0.94	0.936	/	/	/
		mg/L	209	220	207	216	223	233	213	228	218.625	/	/	/
		mg/L	0.006	0.007	0.007	0.006	0.006	0.007	0.006	0.006	0.006	/	/	/
		mg/L	0.015	0.023	0.019	0.015	0.023	0.026	0.023	0.019	0.020	/	/	/
		mg/L	3.21	2.97	3.18	3.09	2.85	2.97	2.71	2.76	2.968	/	/	/
		mg/L	ND	ND	ND	ND	ND	ND	ND	ND	/	/	/	/
		mg/L	0.38	0.39	0.33	0.38	0.4	0.36	0.37	0.41	0.3775	/	/	/
	TDS	mg/L	1880	2040	1770	2110	1800	1930	1720	2020	1908.75	/	/	/
W4	pH		7.6	7.5	7.6	7.6	7.4	7.4	7.3	7.4	7.475	/	6~9	
		mg/L	44	40	45	47	41	48	43	49	44.625	81.61%	200	
		mg/L	18	17	16	20	19	15	17	22	18	68.07%	100	
		mg/L	3.89	4.09	3.74	4.27	3.74	3.61	3.94	4.12	3.93	97.83%	50	
		mg/L	0.41	0.43	0.39	0.42	0.37	0.39	0.38	0.37	0.40	93.46%	1.5	
		mg/L	36	37.6	36.6	37	36.8	38.4	37.6	37.1	37.1	90.86%	60	
		mg/L	0.01	0.011	0.011	0.012	0.012	0.011	0.01	0.011	0.011	41.38%	0.2	
		mg/L	ND	ND	ND	ND	ND	ND	ND	ND	ND	/	0.1	
		mg/L	ND	ND	ND	ND	ND	ND	ND	ND	ND	/	0.5	
		mg/L	ND	ND	ND	ND	ND	ND	ND	ND	ND	/	/	
	TDS	mg/L	1110	951	1270	1020	1050	881	1200	970	1056.5	44.65%	5000	

0.01mg/L

0.2mg/L

50050-2017

GB 13458-2013

**9.2.3**

9.2.3-1

**9.2.3-1 a dB A**

N1		2025.08.24	56.6	51.9	65	55	
N2			55.1	52.3	65	55	
N3			61	54	65	55	
N4			55.7	52.5	65	55	
N1		2025.08.25	60.2	52.5	65	55	
N2			55.4	51.8	65	55	
N3			62.9	51.7	65	55	
N4			56.8	52.7	65	55	

**9.2.3-1 b dB A**

N5		2025.08.24	59.2	53.1	65	55	
N6			60.3	54.6	70	55	
N7			57.4	52.3	65	55	
N8			54.8	52.8	65	55	
N5		2025.08.25	60.8	53.3	65	55	
N6			63	54.4	70	55	
N7			58	52.4	65	55	
N8			56.2	52.9	65	55	

GB12348-2008 3

GB12348-2008 4

**9.2.4**

## 9.2.4-1

			kg/h	(h/a	t/a		t/a
2025.8.12~8.27 2025.11.3~11.4	DA001		0.0103	8000	0.0822	97.55%	0.0843
		NO <sub>x</sub>	0.1850	8000	1.4800		1.5172
		NH <sub>3</sub>	0.0090	8000	0.0716		0.0734
	DA002	H <sub>2</sub> S	0.0040	8000	0.0318	97.55%	0.0326
			0.0494	8000	0.3955		0.4054
		NMHC	0.0215	8000	0.1720		0.1763
	DA003		0.0073	8000	0.0586	97.55%	0.0601
	DA004		0.0081	8000	0.0650	97.55%	0.0666
	DA005		0.0042	8000	0.0333	97.55%	0.0342
	DA006	NH <sub>3</sub>	0.0040	8000	0.0317	52.35%	0.0605
		H <sub>2</sub> S	3.15×10 <sup>-4</sup>	8000	0.0025		0.0048
		SO <sub>2</sub>	0.0252	8000	0.2013		0.3846
		NO <sub>x</sub>	0.0710	8000	0.5680		1.0850
	DA007		0.0408	8000	0.3267	73.55%	0.4441
	DA008		0.0260	8000	0.2080	97.55%	0.2132
	DA009		0.0258	8000	0.2067	97.55%	0.2119
	DA010		0.0263	8000	0.2107	97.55%	0.2160
	DA011	NH <sub>3</sub>	0.6315	8000	5.0520	83.66%	6.0387
	DA012		0.0202	8000	0.1613	71.00%	0.2272
	DA013	NH <sub>3</sub>	0.0023	8000	0.0188	77.33%	0.0243
	DA014	NH <sub>3</sub>	0.1507	8000	1.2053	77.33%	1.5587
	DA015	NH <sub>3</sub>	0.8147	8000	6.5173	77.33%	8.4281
	DA016	NH <sub>3</sub>	2.3800	8000	19.0400	77.33%	24.6223
DA017		0.0058	8000	0.0466	71.67%	0.0651	
DA018		0.0051	8000	0.0404	71.67%	0.0564	
DA019		0.0235	8000	0.1880	71.67%	0.2623	
DA020		0.0137	8000	0.1093	71.00%	0.1540	
DA021		0.0070	8000	0.0564	71.00%	0.0794	
DA022		0.0210	8000	0.1680	75.17%	0.2235	
DA023		0.0265	8000	0.2120	97.55%	0.2173	

			kg/h	(h/a	t/a		t/a
	DA024		0.0042	8000	0.0337	97.55%	0.0346
	DA025		0.0047	8000	0.0380	97.55%	0.0389
	DA026		0.0203	8000	0.1627	97.55%	0.1668
	DA027		0.0092	8000	0.0738	97.55%	0.0757
	DA028		0.0042	8000	0.0337	97.55%	0.0345
	DA029		0.0040	8000	0.0322	97.55%	0.0331
	DA030		0.0275	8000	0.2200	77.33%	0.2845
	DA031		0.0258	8000	0.2067	77.33%	0.2673
	DA032		0.0472	8000	0.3773	71.67%	0.5265
	DA033		0.0373	8000	0.2987	71.67%	0.4167
	DA034		0.0108	8000	0.0862	75.17%	0.1147
	DA035	NH <sub>3</sub>	0.0240	8000	0.1920	77.33%	0.2483
	DA036	NH <sub>3</sub>	0.2355	8000	1.8840	77.33%	2.4364
	DA037	NH <sub>3</sub>	0.0328	8000	0.2627	77.33%	0.3397
	DA038		0.0083	8000	0.0666	97.55%	0.0683
	DA039	NMHC	0.0062	8000	0.0495	75.84%	0.0653
	DA040		0.0007	8000	0.0054	97.55%	0.0055
		NMHC	3.67×10 <sup>-5</sup>	8000	0.0003		0.0003
	DA041	NH <sub>3</sub>	0.0019	8000	0.0153	75.84%	0.0153
			0.0038	8000	0.0307		0.0307
		NMHC	0.0018	8000	0.0141		0.0141
	DA043	NH <sub>3</sub>	0.0001	8000	0.0006		0.0006
			0.0006	8000	0.0047		0.0047
		NMHC	2.49×10 <sup>-4</sup>	8000	0.0002		0.0002
	DA044	NH <sub>3</sub>	2.10×10 <sup>-4</sup>	8000	0.0002		0.0002
			0.0008	8000	0.0061		0.0061
		NMHC	2.94×10 <sup>-4</sup>	8000	0.0003		0.0003
	DA047	NH <sub>3</sub>	3.2×10 <sup>-4</sup>	8000	0.0003		0.0003
			0.0007	8000	0.0055		0.0055
		NMHC	2.52×10 <sup>-4</sup>	8000	0.0003		0.0003
	DA050	NH <sub>3</sub>	0.0008	8000	0.0063		0.0063
			0.0007	8000	0.0056		0.0056
		NMHC	4.75×10 <sup>-4</sup>	8000	0.0005		0.0005
	DA052	NH <sub>3</sub>	3.95×10 <sup>-4</sup>	8000	0.0004		0.0004
			0.0009	8000	0.0068		0.0068
		NMHC	0.0027	8000	0.0214		0.0214
	DA053	NH <sub>3</sub>	0.0004	8000	0.0031		0.0031
			0.0008	8000	0.0064		0.0064
		NMHC	4.92×10 <sup>-4</sup>	8000	0.0005		0.0005

			kg/h	(h/a	t/a		t/a
	DA054	NH <sub>3</sub>	0.0157	8000	0.1253	75.84%	0.1653
		H <sub>2</sub> S	0.0108	8000	0.0867		0.1143
		NMHC	0.0875	8000	0.7000		0.9229

9.2.4-2

9.2.4-2			t/a
	44.6104		4.6768
H <sub>2</sub> S	0.1702		0.1517
SO <sub>2</sub>	2.6596		0.3846
NO <sub>x</sub>	7.1152		2.6022
	52.5006		44.0596
	1.7983		0.5722
NMHC	2.3659		1.2562

9.2.4-1      9.2.4-2

2

9.2.4-3

9.2.4-3				
	mg/L	d	t/a	t/a
	/	333 8000	1054248.4009	1960256
COD <sub>Cr</sub>	44.625		47.0458	424.732
SS	18		18.9765	247.5101
	3.925		4.1379	23.5142
	0.0613		21.0586	41.1499
	19.975		0.0646	0.122
	0.0064		0.0067	0.16
	0.12		0.1265	17.0512
TDS	1056.5		1113.8134	8776.24

# 10

## 10.1

2025 8 12 8 27 2025 11

3 ~11 4

### 1

GB/T19923-2024

GB/T 50050-2017

GB 13458-2013

### 2

DA001

DB32/ 4385-2022

DA002

GB14554-93 2

GB31571-2015 6 NMHC

DB32/4041-2021 1

DA003~DA005

DA008~DA010

DA012

DA023

DA017~DA019

DA022 DA034

DA032

DA033 1#~3#

DA024~DA026

1~3

DA027~DA029

DA020 DA021 DA030 DA031

DA038

DB32/4041-2021 1

DA007

GB31573-2015 4

DA011 DA013~DA016 DA035~DA037

GB14554-93 2

DA040

DB32/3151-2016 1

DA039 NMHC

DB32/4041-2021 1

DA040 DA041 DA043 DA044 DA047 DA050 DA052 DA053

GB14554-93 2 NMHC

DB32/4041-2021 1 DA054

GB14554-93 2 NMHC

DB32/4041-2021 1

DB32/4041-2021 3

GB14554-93 1

DB32/3151-2016 2

DB32/4041-2021 2

3

GB12348-2008 3

GB12348-2008 4

4

5

## 10.2

1

2

3

GB18597-2023

GB 18599-2020

4

						2206-320723-89-01-718313							1
		C2612					<input checked="" type="checkbox"/>		/				119°43 44.69 34°26 13.27
		80 / 30 / 110 / 45000Nm3/ 40 / 100 / 6.5 / 5.4 / 2.2 / 1.2 / 4.8 / 4800 / 1.6 /					80 / 30 / 110 / 40 / 45000Nm3/ 100 / 6.5 / 5.4 / 2.2 / 1.2 / 4.8 / 4800 / 1.6 /						
							2022 6						
		2022 6					2025 4						2025.2.11
													91320700MA1MFBW0003V
							582805.24						1.62%
							447300						1.92%
		7234		2251.0 98		90.69		500		760			707.2
				/				8200m³/h 6000m³/h					8000h
								91320700MA1MFBW470					2025 8
		<b>1</b>	<b>2</b>	<b>3</b>	<b>4</b>	<b>5</b>	<b>6</b>	<b>(7)</b>	<b>“ ” (8)</b>	<b>(9)</b>	<b>(10)</b>	<b>(11)</b>	<b>(12)</b>
		/	/	/	/	/	1054248.4009	/	/	1054248. 4009	1960256	/	/
		/	/	/	/	/	47.0458	/	/	47.0458	424.732	/	/
		/	/	/	/	/	4.1379	/	/	4.1379	23.5142	/	/
		/	/	/	/	/	0.1265	/	/	0.1265	17.0512	/	/
		/	/	/	/	/	/	/	/	/	/	/	/
		/	/	/	/	/	0.3846	/	/	0.3846	2.6596	/	/

		/	/	/	/	/	4.6768	/	/	4.6768	44.6104	/	/
		/	/	/	/	/	2.6022	/	/	2.6022	7.1152	/	/
		/	/	/	/	/	/	/	/	/	/	/	/
	<b>VOCs</b>	/	/	/	/	/	1.2562	/	/	1.2562	2.3659	/	/
		/	/	/	/	/	0.1517	/	/	0.1517	0.1702	/	/
		/	/	/	/	/	44.0596	/	/	44.0596	52.5006	/	/
		/	/	/	/	/	0.5722	/	/	0.5722	1.7983	/	/
	<b>SS</b>	/	/	/	/	/	18.9765	/	/	18.9765	247.5101	/	/
	<b>TN</b>	/	/	/	/	/	21.0586	/	/	21.0586	41.1499	/	/
	<b>TP</b>	/	/	/	/	/	0.0646	/	/	0.0646	0.122	/	/
		/	/	/	/	/	0.0067	/	/	0.0067	0.16	/	/
		/	/	/	/	/	1113.8134	/	/	1113.8134	8776.24	/	/

$$\frac{1}{\text{---}} / + \frac{-}{\text{---}} / \frac{2}{\text{---}} \frac{(12)=(6)-(8)-(11)}{\text{---}} \frac{9}{\text{---}} \frac{=(4)-(5)-(8)-(11)+1}{\text{---}} \frac{3}{\text{---}} / \text{---} / \text{---} / \text{---} /$$

**1**

**1.1**

**1.2**

**1.3**

2022 5

2022 5 28

2022 6

2025

11 2025 11 29

**1.4**

**2**

**2.1**

1

2

3

**2.2**

1

2

200m

**2.3**

**3**